

# Polypipe Building Products

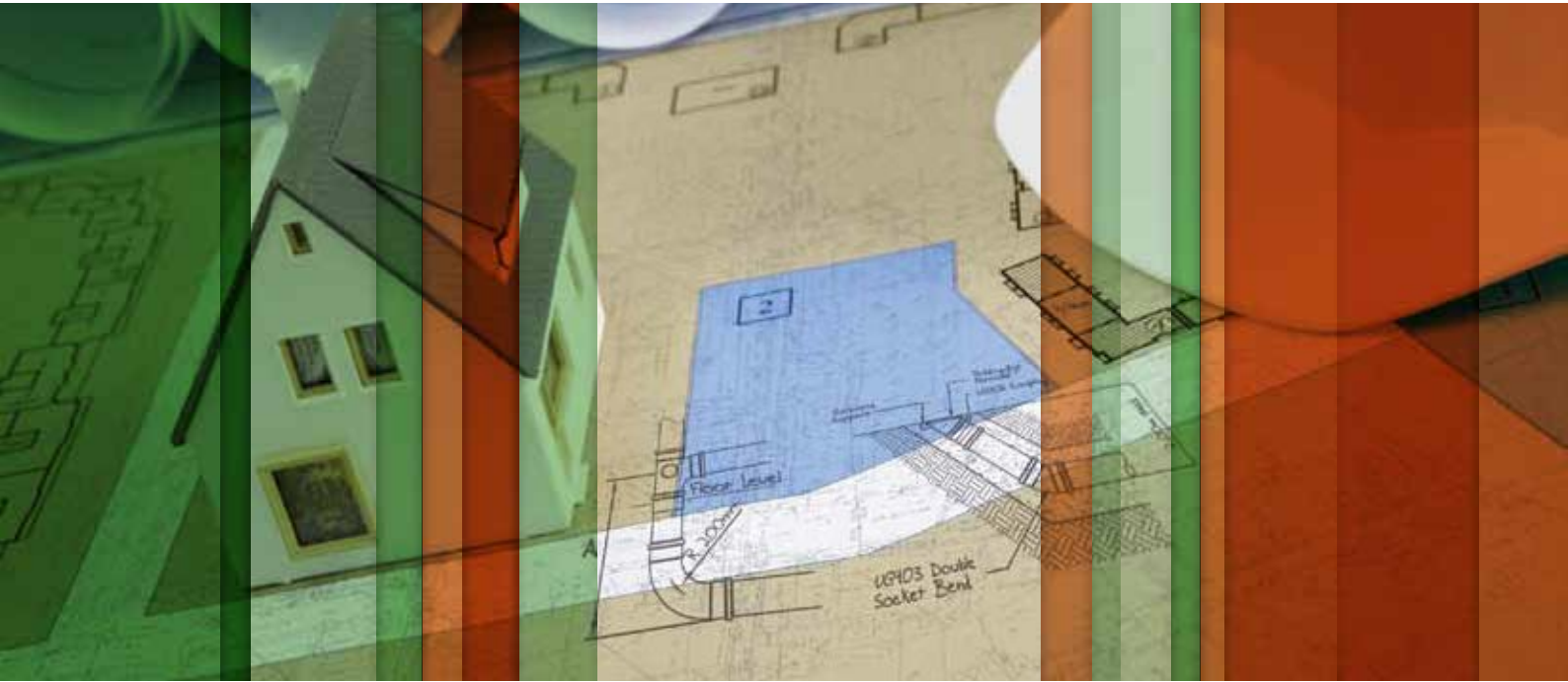

## Technical Installation Guide

### Above & Below Ground Drainage



# INTRODUCTION

## POLYPIPE IS ONE OF EUROPE'S LARGEST AND MOST INNOVATIVE MANUFACTURERS OF PLASTIC PIPING SYSTEMS FOR RESIDENTIAL, COMMERCIAL AND INFRASTRUCTURE SECTORS.



With an enviable reputation for a broad product range, reliability and value, whether our customers need pipes to carry water, air, energy, telecoms or chemicals, Polypipe can provide the ideal plastic piping system solution to deliver the goods



### Polypipe Building Products

Polypipe Building Products offer a comprehensive range of above and below ground drainage products, plastic plumbing and underfloor heating systems for the residential market.

This Technical Installation Guide covers Above and Below Ground systems and is produced in an easy to follow, logical format.

See page 43 for information on other systems available from Polypipe Building Products.

### Further Assistance

If you need any further help or advice, please contact:

Technical Advice: **01709 770 000 - option 2**

Sales/Delivery: **01709 770 000 - option 1**

Contact your local Polypipe Area Manager

Alternatively please visit our website at [www.polypipe.com/bp](http://www.polypipe.com/bp) and follow the Literature Downloads link.

### Feedback

Your feedback is important to us, if you have any comments or suggestions of how we can improve this guide, please forward them to [info@polypipe.com](mailto:info@polypipe.com) with a subject heading of "DTIG1 feedback"

# CONTENTS

<b>ABOVE GROUND SYSTEMS</b>	<b>4 - 27</b>
Introduction	4
Above Ground Systems Contents	5
Soil & Waste Systems	6 - 17
Traps	18 - 20
Rainwater Systems	21 - 27

<b>BELOW GROUND SYSTEMS</b>	<b>28 - 42</b>
Introduction	28
Below Ground Systems Contents	29
Drainage	30 - 38
Inspection Chambers	39 - 41
Polysewer	42

## CERTIFICATES AND APPROVALS

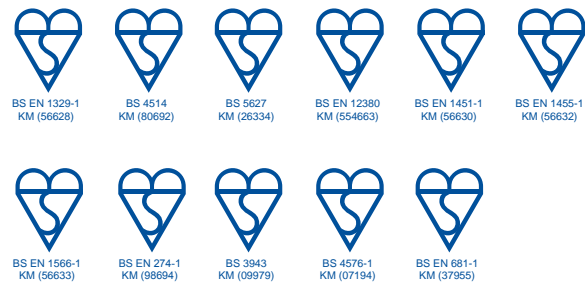

Certificate No	Kitemark Licence	Product
BS EN 1329-1	KM 56628	PVCU soil pipes & fittings
BS 4514	KM 80692	PVCU soil pipes & fittings
BS 5627	KM 26334	PP WC connectors
BS EN 12380	KM 554663	Air admittance valves
BS EN 1451-1	KM 56630	PP Waste Pipes & Fittings
BS EN 1455-1	KM56632	ABS waste pipe & fittings
BS EN 1566-1	KM 56633	MUPVC waste pipe
BS EN 274-1	KM 98694	PP waste traps
BS 3943	KM 09979	PP waste traps
BS 4576-1	KM 07194	PVCU half round rainwater systems
BS EN 681-1	KM 37955	EDPM rubber seals

## CERTIFICATES AND APPROVALS



Certificate No	Kitemark Licence	Product
BS 4660	KM 59284	PVCU underground drainage/sewers
BS EN 1401-1	KM 06383	PVCU underground drainage/sewers
BS 7158	KM 61546	PP inspection chambers
BS EN 295	KM 506831	Flexicon Couplings/Band Seal Couplings
WIS 4-35-01	KM 55698	Polysewer pipes/couplers
WIS 4-41-01	KM 506832	Flexicon band couplings



BBA Certificate No	Product
89/2206	PVCU underground drainage
02/3928	Polysewer fittings



BBA Certificate No	Product
09/4650	Polyvalve air admittance valves
91/2673	PVCU rainwater systems (now includes Sovereign)

All images shown are for illustrative purposes only. All products are subject to availability. E & O E. All information is correct at the time of publication. Polypipe reserve the right to change or amend specification details without prior notice. The contents herein are manufacturers guidelines only and it remains the users responsibility to determine the suitability of any product or installation guidelines contained herein, are fit for the intended purpose.





# ABOVE GROUND DRAINAGE

Polypipe offers a comprehensive range of Above & Below Ground Drainage products incorporating all necessary systems required for the disposal and redistribution of waste water and rainwater.

Our PVCu soil and vent systems include ring seal and solvent weld options accompanied by a wide range of Kwickfit or solvent weld WC pan connectors, air admittance valves and fire protection sleeves.

Our waste range is the most comprehensive available in the UK market with four different ranges and a complete range of kitemarked waste traps.

Polypipe manufactures three types of plastic waste systems with diameters as detailed below:

- Polypropylene push-fit system - outside diameters of 34.6mm, 41.0mm and 54.1 mm (EN1451-1).
- ABS solvent waste system - outside diameters of 36.3mm, 43.0mm and 55.9mm (EN1455-1).
- MUPVc System 2000 waste system - outside diameters of 36.3mm, 43.0mm and 55.9mm (EN1329-1 for fittings & EN1566-1 for pipe).

For rainwater systems in PVCu we offer a choice of nine different profiles with five colour alternatives, providing a technical solution with aesthetic alternatives for all residential and light commercial properties.



## ABOVE GROUND SYSTEMS

4 - 27

### Introduction

4 - 5

Certificates and Approvals

3

### Soil & Waste Systems

6 - 17

Pipework Dimensions and Weights

6

Temperature Resistance

6

Methods of Jointing

7

Pipework Support Centres

7

Thermal Movement & Expansion Joints

8

Sanitary Pipework Design

8

Connections to Base of Stacks

8

Stub Stacks

8

WC Connection Direct to Drain

8

Prevention of Crossflow

9

Access to Pipework

9

Suspended Soil System Pipework

10

Cross Bracing

10

Boss Connections

11

WC Connectors

11

Branch Connection, Pipe Lengths and Gradients

12

Soil Manifold

12

Air Admittance Valves

13 - 14

Termination of Soil Stacks

15

Weathering Slates for Pitched Roofs

15

Fire Protection

16

Soil System Testing

17

### Traps

18 - 20

Types of Traps

19 - 20

### Rainwater Systems

21 - 27

Gutter and Downpipe Systems

21

Handling & Storage

22

Calculating Roof Areas

22

Gutter Selection

22 - 23

Jointing Brackets & Supports

23 - 25

Downpipe Installation

26

Connection to Other Materials

26

Connection to Drainage Systems

27



# SOIL & WASTE SYSTEMS

## SOIL AND WASTE SYSTEM PIPEWORK DIMENSIONS & WEIGHTS

TABLE 1: SOIL AND WASTE SYSTEM PIPEWORK DIMENSIONS & WEIGHTS

Product	Outside Diameter (mm)	Wall Thickness (mm) Min	Weight Per Metre (kg) Min
82mm Soil BS4514	82.40	3.20	1.18
110mm Soil BS EN 1329-1	110.00	3.20	1.59
160mm Soil BS EN 1329-1	160.00	3.20	2.33
32mm PP Push-fit Waste BS EN 1451-1	34.60	1.80	0.17
40mm PP Push-fit Waste BS EN 1451-1	41.10	1.90	0.21
50mm PP Push-fit Waste BS EN 1451-1	54.10	2.00	0.29
32mm ABS Solvent Waste BS EN 1455-1	36.30	1.80	0.20
40mm ABS Solvent Waste BS EN 1455-1	43.00	1.90	0.25
50mm ABS Solvent Waste BS EN 1455-1	55.90	2.00	0.35
32mm MUPVC Solvent Waste BS EN 1566-1	36.30	1.80	0.29
40mm MUPVC Solvent Waste BS EN 1566-1	43.00	1.90	0.36
50mm MUPVC Solvent Waste BS EN 1566-1	55.90	2.00	0.50

## TEMPERATURE RESISTANCE

Polypipe traps, waste and soil systems are suitable for short intermittent discharges of hot and cold water in normal domestic installations in the UK. They are not suitable for continuous discharge at elevated temperatures. The integrity of the joints

and the materials of the systems are confirmed by carrying out the thermal cycling tests which are included in the relevant British and European standards which are quoted in the standards section of this document.







# SOIL & WASTE SYSTEMS

## METHODS OF JOINTING

### PUSH-FIT (Ring Seal) JOINTING

1. Where plain end pipe is being used, ensure that the pipe is cut square to its axis and that all burrs are removed.
2. Chamfer the end of the pipe to prevent the ring seal being damaged or displaced when the pipe is inserted into the socket. Fittings with spigot ends are moulded with a chamfer during manufacture.
3. Lubricate the spigot or ring seal with Polypipe silicone grease or aerosol lubricant.
4. Insert the pipe or fitting into the socket and then withdraw it by approx. 10mm to allow for expansion of the pipework.

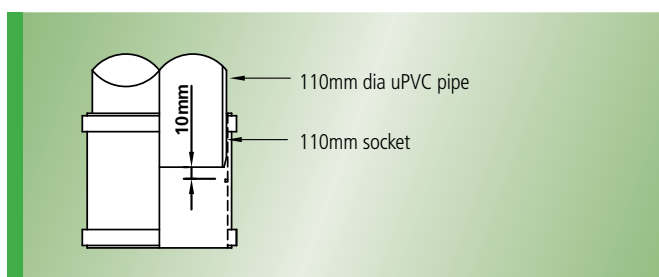

### SOLVENT WELD JOINTING

1. Ensure that the pipe is cut square and that all burrs are removed.
2. Ensure that both surfaces to be jointed are dry and free from dust or other debris.
3. Use Polypipe cleaning fluid CF250 to remove any surface grease from the spigot and socket to be jointed.
4. Apply a coat of Polypipe solvent cement to both surfaces to be jointed using the brush applicator provided in the lid. The cement should be applied along the length of the spigot and not around its diameter.
5. The spigot should be inserted into the socket immediately, with a slight twisting action.
6. Any surplus solvent cement should be removed with a clean cloth.
7. The joint will be strong enough to handle after approx. 5 minutes and can be tested after 12 hours.

Gap filling solvent cement (GFC100) used to fit components such as strapped saddle bosses.

The following table indicates the approximate number of joints that can be made for each pipe diameter with solvent cement, cleaning fluid and silicone grease.

TABLE 2: NUMBER OF SOLVENT CEMENT JOINTS FOR PIPE DIAMETERS

	Pipe Diameters						
	19mm	32mm	40mm	50mm	82mm	110mm	160mm
Solvent Cement 125ml Code SC125	85	45	35	20	9	5	3
Solvent Cement 250ml Code SC250	175	90	70	40	18	10	6
Solvent Cement 500ml Code SC500	350	180	140	80	35	20	12
Cleaning Fluid 250ml Code CF250	250	140	120	75	30	20	15
Silicone Grease 100gm Code SG100	-	100	85	45	35	20	10

## PIPEWORK SUPPORT CENTRES

The following table shows recommended maximum pipe support centres for horizontal and vertical pipework:-

TABLE 3: PIPE SUPPORT CENTRES

	Pipe Diameters						
	19mm	32mm	40mm	50mm	82mm	110mm	160mm
Horizontal	0.6m	0.5m	0.5m	0.5m	0.9m	0.9m	0.9m
Vertical	0.6m	1.2m	1.2m	1.2m	1.8m	1.8m	1.8m



# SOIL & WASTE SYSTEMS

## THERMAL MOVEMENT AND EXPANSION JOINTS

Pipe sockets should be securely anchored to the structure to prevent excessive thermal movement.

Expansion and contraction can take place between pipe sockets by providing an expansion allowance every 4m within the pipework run. Intermediate pipe brackets should not hold the pipe so securely so as to unduly restrict expansion and contraction.

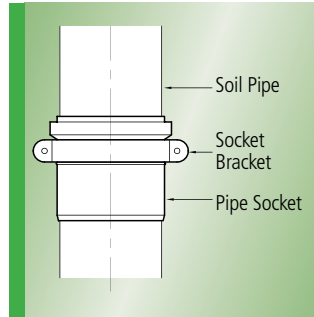

1. Ensure that the pipe spigot is cut square, chamfered and free from burrs.
2. Push the pipework into the socket until the central stop within the fitting is reached.
3. Mark a pencil line on the pipework at the socket face.
4. Withdraw the pipework from the socket by 10mm.

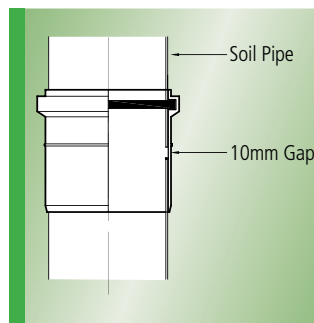

Ring seal adaptors (e.g SWE 99) are available in the System 2000 range which enable most solvent soil sockets to be converted to a ring-seal expansion joint. Expansion couplers are available in the ABS and MUPVC ranges to provide expansion provision.

## SANITARY PIPEWORK DESIGN

Soil and ventilation systems should be designed in accordance with Document H of the current Building Regulations for England and Wales and corresponding regulations for Scotland and Northern Ireland. System design should also conform to the Code of Practice BS EN 12056:2:2000, 'Sanitary pipework, layout and calculation'.

These publications cover requirements such as ventilating pipework, flow rate calculations, system configurations and capacities of drains.



## CONNECTIONS TO BASE OF STACKS

The minimum vertical distances between connections to the stack and the invert of the underground drainage system are shown below:-

A = 450mm min for buildings up to 3 storeys

750mm min for buildings of 4 and 5 storeys

For buildings between 5 and 20 storeys, the ground floor appliances should connect direct to drain or to their own soil stack.

For buildings over 20 storeys, both the ground and first floor appliances should connect to their own soil stack.

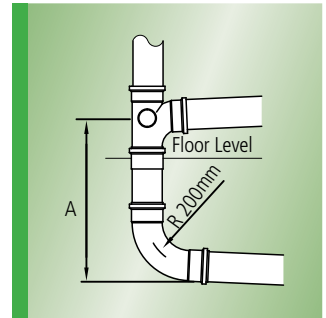

## STUB STACKS

For ground floor appliances, a short unventilated stack may be used, provided it discharges into a ventilated drain and distances do not exceed those shown in the diagram below. Stub stacks may also be used on upper floors where the discharge from the stack is to a ventilated soil stack.

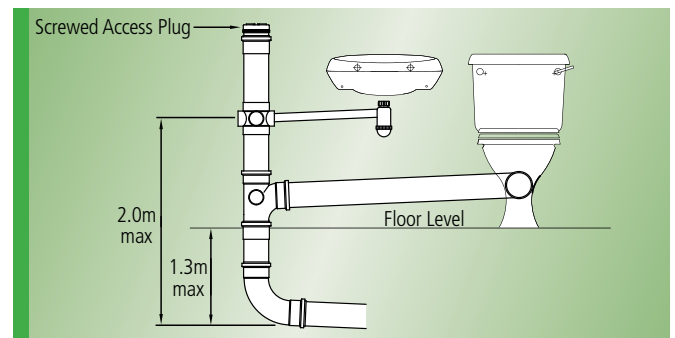

## WC CONNECTION DIRECT TO DRAIN

A WC should only connect directly to the drainage system if the depth from floor level to the invert of the drain is less than 1.3m.

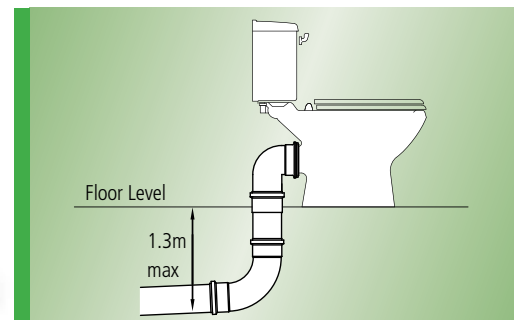





# SOIL & WASTE SYSTEMS

## PREVENTION OF CROSSFLOW

Where a branch enters a stack, it creates a zone on the opposite wall of the stack where no connections may be made.

Where the branch pipe diameter is less than 65mm, the no connection zone is 110mm deep on a 110mm diameter stack and 250mm deep on a 160mm diameter stack, measured from the centre line of the incoming branch pipe.

Where the branch pipe exceeds 65mm, the no connection zone is 200mm irrespective of stack diameter.

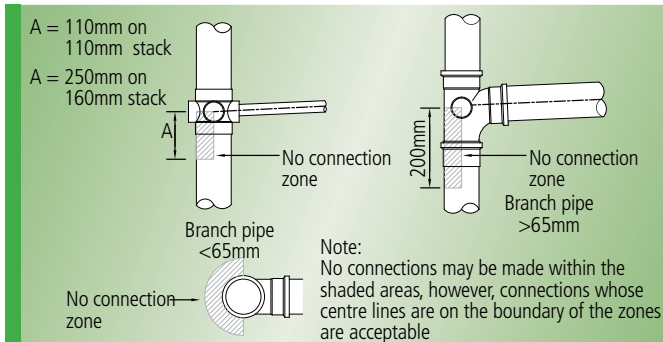

## ACCESS TO PIPEWORK

Where the discharge stack has a long drain connection to an inspection chamber, access for rodding and testing should be provided at or near the base of the stack. When ground floor appliances are connected to the soil stack, the access point should be sited above the spillover level of the appliances.

For multi-storey domestic buildings, access into the stack should be provided at 3 storey intervals and for multi-storey commercial buildings access should be provided on each floor.

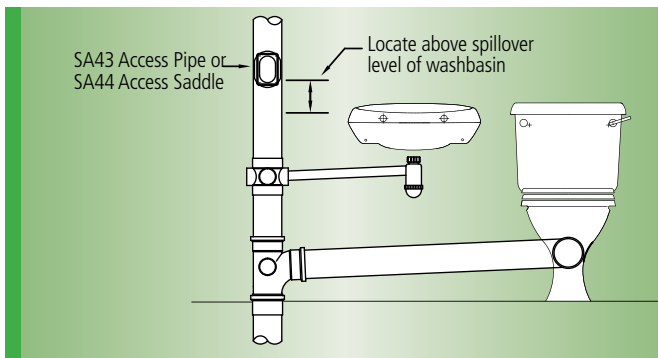



# SOIL & WASTE SYSTEMS

## SUSPENDED SOIL SYSTEM PIPEWORK

### General Information

**PURPOSE:** To ensure that, where soil drainage pipework has to pass through an undercroft or basement area:

- it is properly supported throughout any suspended run
- its integrity is maintained and protected from the consequences of thermal expansion or contraction

### Recommended Support Centres

See page 7.

### Fixing Details

Fit intermediate support brackets for suspended pipework at recommended centres. These may be attached to 8mm drop rods (supplied by others) fixed into the ceiling or soffit above the pipework.

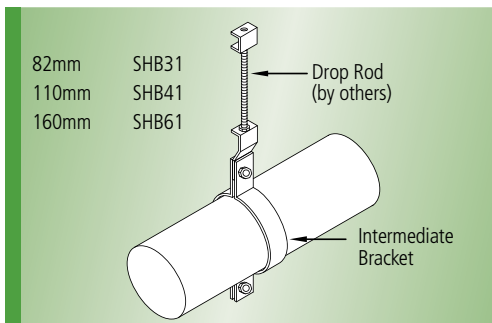

Install expansion joints at recommended centres along the suspended pipe run. Where the suspended run is lengthy, the expansion joints must be installed with a Thermal Movement Limiter.

### Installation of Thermal Movement Limiter

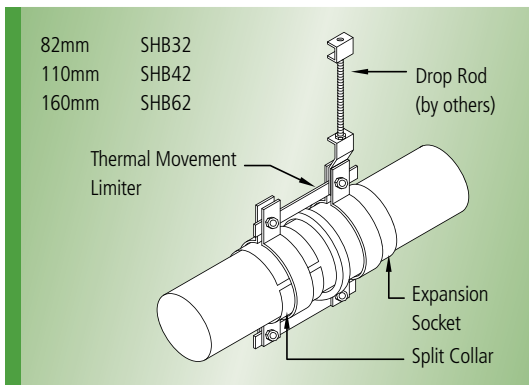

### Step 1 -

Clean the surface of the pipe upstream of the expansion socket, and the inner surface of the PVC-u split collar with cleaning fluid using a dry, clean, natural fibre cloth (NOT synthetic).

### Step 2 -

After setting a 10mm expansion gap, solvent weld the split collar to the pipe ensuring that, when assembled, the bolts pass through the centre of the restraining bar slots.

### Step 3 -

Assemble and locate brackets: one around the split collar and the other around the expansion socket.

### Step 4 -

Couple the brackets together with the two slotted retaining bars (which restrict horizontal movement to 25mm). Assemble these so that the slotted ends are above and below the expansion socket

### Step 5 -

Incorporate the link eye (for attachment to drop rod or ceiling/soffit fixing) with the upper restraining bar.

### Step 6 -

Check that the slotted end of each restraining bar is free to move, and tighten brackets so that they achieve a firm grip on the pipework

### Step 7 -

Connect assembly to drop rod and ceiling/soffit

## CROSS BRACING

When branches enter a main run, cross bracing is necessary to stabilise the system.

### Thermal Movement Limiter assembly with cross bracing.

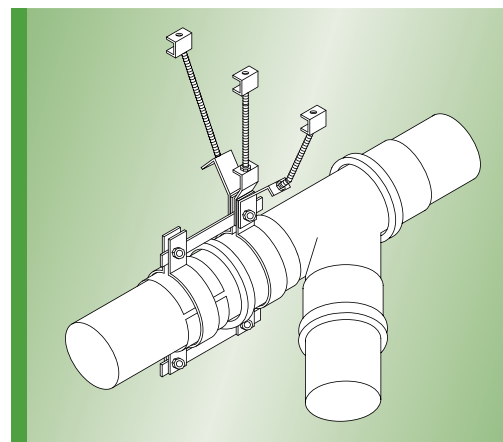



# SOIL & WASTE SYSTEMS

## BOSS CONNECTIONS

All boss shoulders provided on bossed pipes, branches, strap bosses etc. are a common size and will accept 32mm, 40mm and 50mm waste pipes using a comprehensive range of boss adaptors.

Where a boss shoulder is moulded solid, it should be drilled through with a 60mm diameter hole saw.

**Note:** Boss Adaptors with universal push-fit or compression joints will accept polypropylene, ABS, muPVC or copper waste pipes.

### STRAIGHT/ANGLED BOSS ADAPTOR

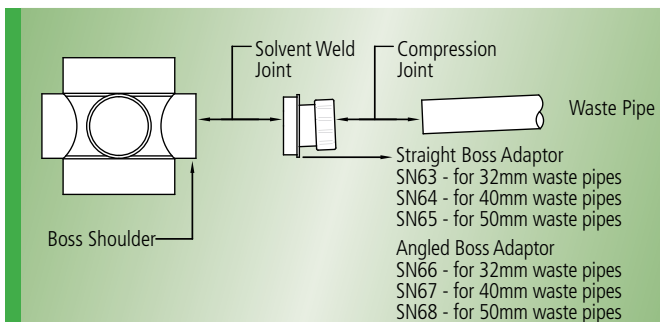

### BOSS ADAPTOR (RUBBER)

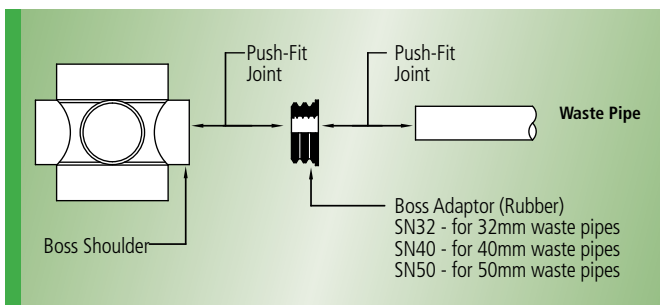

### BOSS ADAPTOR (SOLVENT)

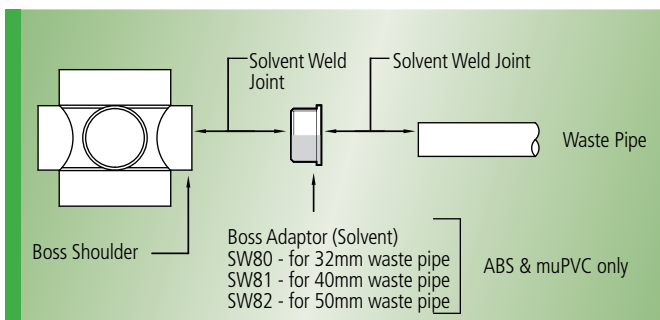

## WC CONNECTORS

A comprehensive range of WC connectors is available for all applications, manufactured from both Polypropylene and uPVC. The inlet sockets on all types are designed for use with horizontal outlet WC pans to BS5503.

For full details of types available, refer to product range information as shown in the current price list.

### KWICKFIT WC PAN CONNECTORS

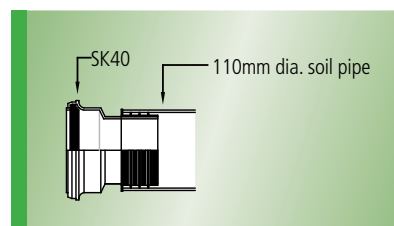

Kwickfit pan connectors are manufactured from polypropylene and are fitted with a flexible EPDM seal for connection directly into plain end soil pipe. This range is available in straight, 90°, 104°,

swivel, offset and flexible versions.

Pancon WC connectors are manufactured from polypropylene and all versions have a 110mm spigot outlet for connection to a ring-seal soil system socket. This type of connector is not suitable for solvent welding

### PANCON WC PAN CONNECTORS

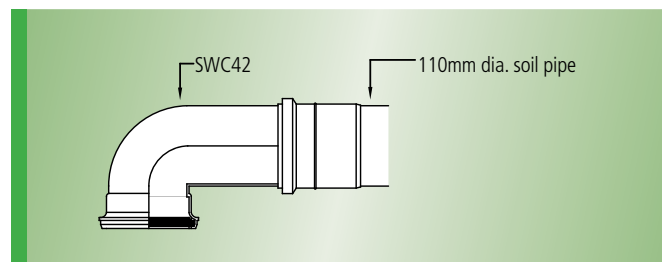

Solpan WC connectors are manufactured from uPVC and are available with spigot or solvent socket outlets for connection to 110mm soil pipe. This type of connector is suitable for solvent welding.

### SOLPAN WC PAN CONNECTORS

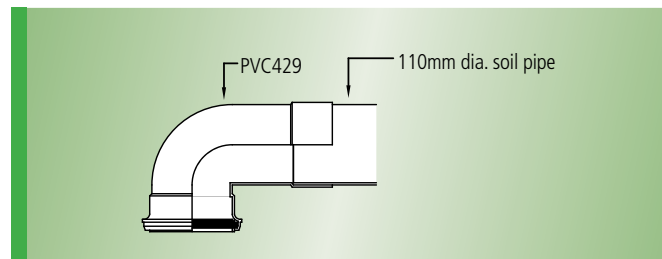





# SOIL & WASTE SYSTEMS

## BRANCH CONNECTION, PIPE LENGTHS AND GRADIENTS

The following information shows the requirements of the Building Regulations with regard to lengths of unventilated branch discharge pipes and corresponding gradients.

### Requirement for single WC

1. A maximum of 8 WC's may be connected to an unventilated soil branch. The length is limited to 15m max. in this case
2. Pipe diameter = 110mm
3. It is only permitted to use 82mm dia. pipework when the outlet of the WC pan itself is less than 80mm diameter

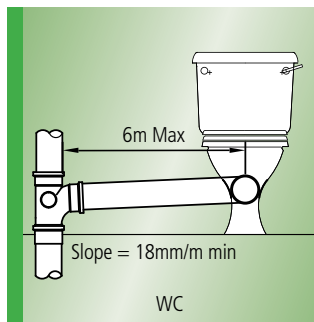

### WASHBASIN (ALSO BIDET)

1. Where maximum length is exceeded, an anti-siphon trap or anti-siphon unit should be used
2. Pipe diameter = 32mm
3. If 40mm dia. pipe is used, max length is 3m

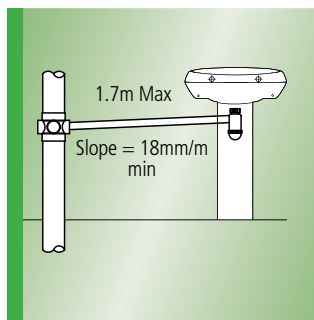

### BATH (ALSO SHOWER)

1. Pipe diameter = 40mm
2. If 50mm dia. pipe is used, max length is 4m

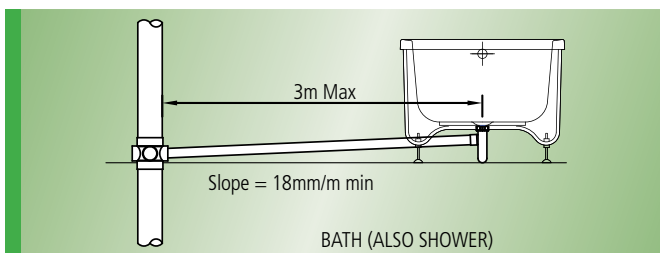

### SINK

1. Pipe diameter = 40mm
2. If 50mm dia. pipe is used, max length is 4m

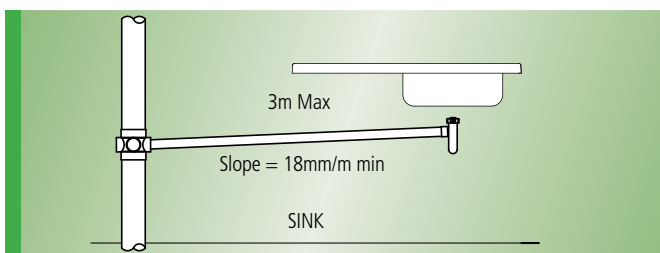

## SOIL MANIFOLD

The MAN5 Soil Manifold overcomes the problem of crossflow whilst maintaining the facility to connect waste pipes to the soil stack above floor level.

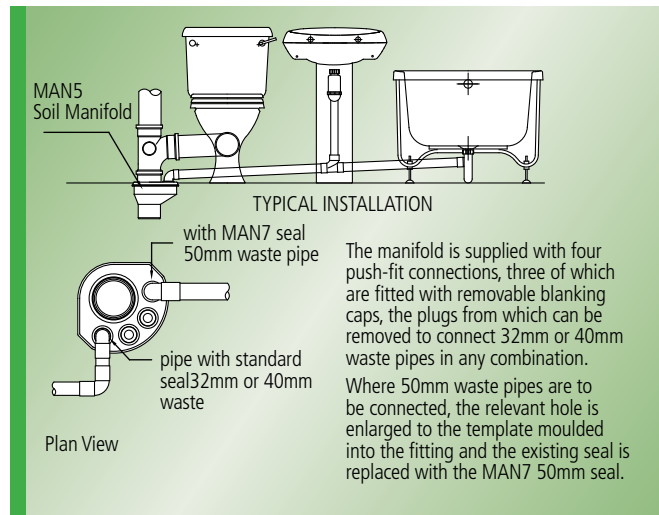



# SOIL & WASTE SYSTEMS

## AIR ADMITTANCE VALVES

An alternative to conventionally venting and terminating a soil stack is the use of an air admittance valve. These valves are designed to reduce the number of vent pipes in a building, which would normally be vented through the roof to atmosphere.

When installed, the valves are in the closed position and will prevent foul air escaping from the pipework system in normal atmospheric conditions or when positive pressure is created in the soil stack or waste pipes, created by the discharge from appliances or fluctuations in pressure within the drainage system. When negative pressure is encountered, the valve will automatically open and allow air to enter the stack, equalising pressures and therefore preventing loss of water seals in the traps on appliances.

110mm and 82mm valves are for use on soil stacks in buildings up to five storeys in height and the 32mm, 40mm and 50mm valves are for use on branch discharge pipes.

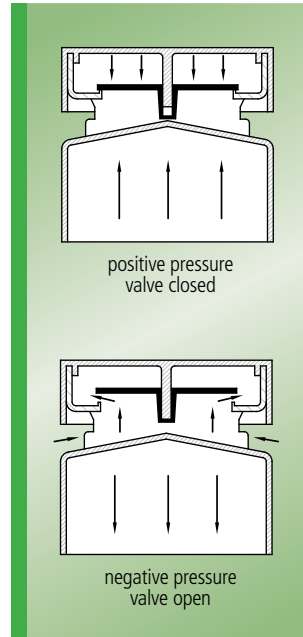

Valves are available in sizes detailed as follows and assessed under BBA Agrément Certificate no. 09/4650

TABLE 4: VALVE SIZES AND POLYPIPE CODES

	PVC-u Solvent Socket		ABS Solvent Spigot to BS EN 1455-1			ABS Push-fit Spigot to BS EN 1451-1		
Size	82mm	110mm	32mm	40mm	50mm	32mm	40mm	50mm
Code	SPV82	SPV110	PVS32	PVS40	PVS50	VWP32	VWP40	VWP50
Air Flow Rate (l s <sup>-1</sup> )	40.1	43.2	6.6	8.1	9.5	6.6	8.1	9.5





# SOIL & WASTE SYSTEMS

## SITING OF AIR ADMITTANCE VALVES

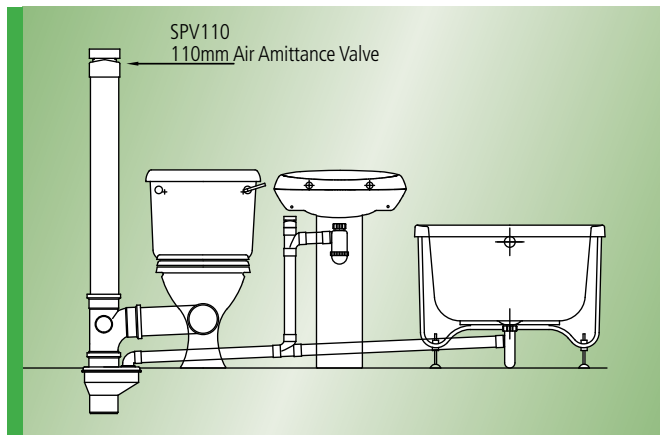

1. Valves should be fitted in a vertical position above the pipe being ventilated.
2. The valves should be installed within the building, preferably in a freely ventilated, non-habitable space such as a duct or roof space or externally to the building where they are protected from dust, insects and are easily accessible but not likely to be subject to interference, e.g. from vandals.

Where the valve is installed in a duct, holes should be provided to allow an air supply to the valve.

3. An air admittance valve should not be used on a stack that provides the only means of ventilation to a septic tank or cess pool.
4. 82mm and 110mm Air admittance valves are supplied with an expanded polystyrene insulative shroud. The shroud should be left in position on the valve where there is a possibility of condensation forming and freezing within the valve body.
5. To prevent induced siphonage in a row of washbasins, a 40mm or 50mm air admittance valve should be fitted between the two washbasins furthest from the stack.
6. In all installations, stacks should not be fitted with air admittance valves where the connecting drain(s) are subject to periodic surcharging or are fitted with intercepting traps. In this case a conventionally vented stack should be used.
7. It is recommended that all air admittance valves are tested for airtightness before installation, i.e. the valves should float when supported in an upright position in a bowl of water.

## Installation to prevent self-siphonage

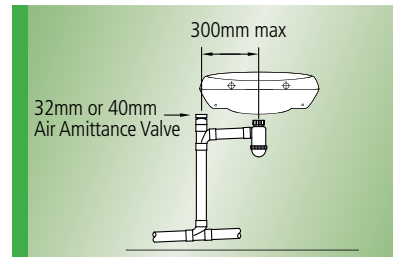

## Installation to prevent induced siphonage

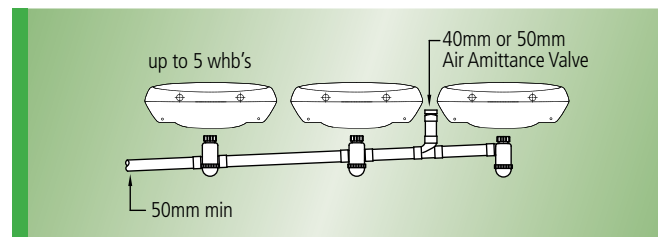

## DRAIN VENTILATION PROVISION

1. For up to and including four dwellings, one, two or three storeys in height, additional drain venting is not required.
2. For five to 10 dwellings, a conventional vent stack should be provided at the head of the drain run.
3. For eleven to 20 dwellings, a conventional vent stack should be provided at the mid-point and head of the drain run.
4. For multi-storey domestic dwellings (other than those referred to above) and non domestic buildings, conventional drain venting should be provided if more than one such building, each equipped with the valves, is connected to either a common drain, itself not vented by means of a ventilation stack, or to a discharge stack not fitted with a valve.

## INSTALLATION TO 20 DWELLINGS

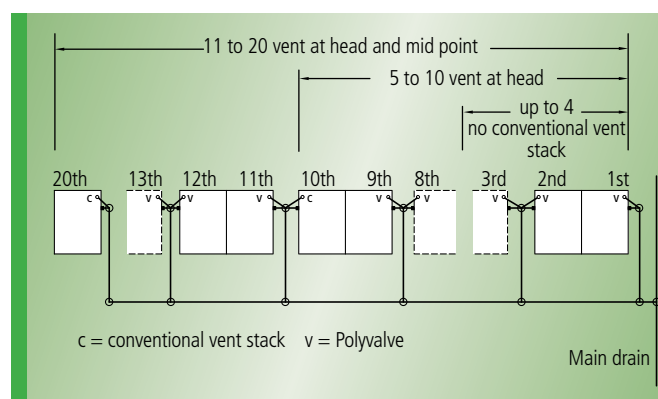





# SOIL & WASTE SYSTEMS

## TERMINATION OF SOIL STACKS

Ventilating pipes open to outside air should finish at least 900mm above any opening into the building within 3m and should be terminated with a perforated cover fixed to the end of the pipe, which does not restrict the flow of air into the system.

The diameter of the stack should preferably remain constant throughout its length. However, a 110mm diameter soil pipe may be reduced to 82mm above the topmost connection without unduly affecting the airflow into the stack. The diameter of a vent pipe on a branch connection can be reduced to 50mm for a 110mm branch.

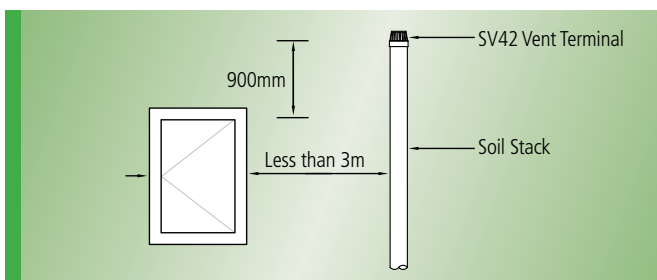

## WEATHERING SLATES FOR PITCHED ROOFS

Where a soil pipe passes through a roof it must be weathered to prevent rainwater passing into the building along the pipe wall.

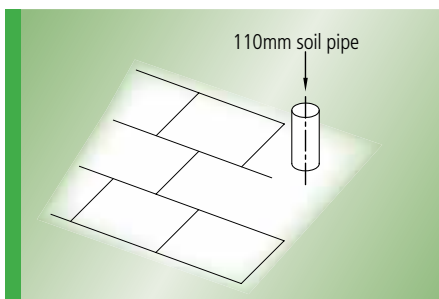

This can be achieved by the use of a rubber/aluminium roof weathering slate which can be dressed to the profile of the roof tiles or slates.

The weathering slate can be pushed over the top of the soil pipe ensuring that there are no sharp edges which could damage the rubber sleeve. The slate is aligned with the lower tiles.

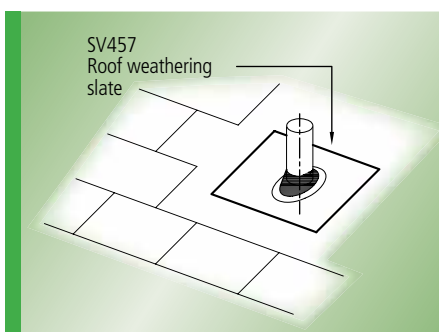

The base plate is dressed to the profile of the lower tiles with the side and upper tiles laid over the top of the base plate. On low pitched roofs, a single welt can be made to the lower edge of the base plate to provide extra strength.

The base plate may be trimmed if required, provided that at least 150mm of weathering remains.

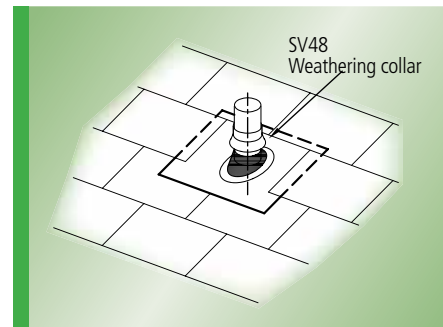

A weathering collar is placed over the stack and solvent welded into position directly above the weathering slate.

If the roof slate is installed on a roof with interlocking tiles, boards or additional battens may be required underneath the weathering slate. The stack must pass through one only course.

To complete the installation, a vent terminal is solvent welded to the top of the stack

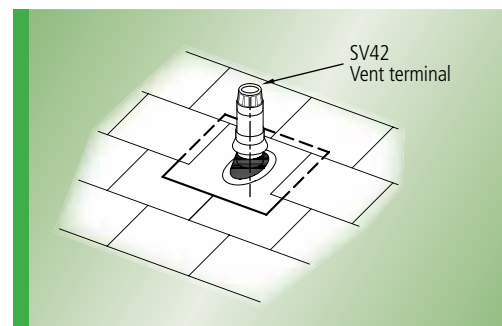



# SOIL & WASTE SYSTEMS

## FIRE PROTECTION

Polypipe pipe collars have been specifically designed to re-instate the fire resistance of a wall or floor which has been penetrated by services such as flammable plastic pipes used in soil, waste and drainage services.

Polypipe pipe collars will seal closed flammable pipes from 50mm to 160mm diameter and can be face fixed or set-in to a wall or ceiling structure. They are suitable for use on concrete, masonry and plasterboard partitions.

Polypipe pipe collars are available with a fire rating of 4 hours and feature a tab closing device which ensures they are quick and easy to fix in place.

Polypipe pipe collars are tested to BS476 Part 20:1987 and many other International Standards.

### Field of Application

Polypipe pipe collars have been specifically designed to prevent the passage of fire and hot gases through:

- Concrete, masonry and plasterboard partitions.
- Concrete floor constructions.
- Soil, waste and drainage 'above ground' applications.

### Product Features

- Collars have achieved a fire rating of 4 hours.
- 4 hour collar has a stainless steel outer casing.
- Tab closing device means collars are easy to fix in place around pipe and rotate or slide into position.
- Intumescent material is totally unaffected by water, is robust, 'non-flaking' and difficult to tear.

### Product Testing

Polypipe have carried out numerous independent fire resistance tests to confirm the suitability of the product and to demonstrate product compliance by utilising BS476: Part 20:1987 and other international standards.

The reports have been consolidated in Assessment Report No. FEA/F98105 and this is available on request from Polypipe Building Products.

### Products Available

TABLE 5: POLYPIPE FIRE PROTECTION PRODUCTS AVAILABLE

Product Code	Pipe Diameter (mm)	Fire Rating
FPS55/4	55	4 Hour
FPS82/4	82	4 Hour
FPS110/4	110	4 Hour
FPS160/4	160	4 Hour

## Installation Instructions

Check the likely direction of the fire. In some cases, two collars may need to be fitted to prevent the fire spread.

1. Ensure that the substrate around the penetration is flat and free from any obstructions, which may prevent the correct installation of the collar. Beware of any obstructions, which may interfere with the fixing tags. If the substrate is uneven it may be necessary to first render the substrate with mortar or some form of rendering material.
2. Any residual gaps, which are smaller than 3mm around the service penetration will need to be filled, this can be done by using intumescent acrylic material, ensure that the gap is completely back filled. For any gaps which are greater than 3mm the penetration should be back filled using mortar or some other form of rendering material.
3. Remove the Polypipe pipe collar from its packaging, and remove the retaining pin.
4. Using both hands open the collar by sliding the tab through the slot, this will release the collar 'open' to allow installation.
5. Using both hands fit the collar around the pipe by sliding the tag through the slot. Once through, ensure that the collar is firmly fitted around the pipe and that the two sections of the collar meet.
6. The tag can now be folded back through 180° and once completed the collar can be moved towards the substrate. Correct fitting can be achieved by rotating and pushing the collar, in some instances the collar can be slid into place.
7. Once the collar has been presented to the substrate it can be securely fitted. Using a drill, fitted with a masonry bit, place the drill in the circular-fixing hole of the fixing tag and commence drilling to the required depth. This usually is 65mm deep into the substrate and remove any debris from the hole. Using M8 x 65mm sleeve anchors (not plastic), place the anchor in the hole and using a hammer lightly tap the anchor into position. Tighten the sleeve anchor firmly to fix into position. Repeat this procedure, until all fixings tags have been fitted.
8. When the collar has been securely fitted into place any residual gaps between the collar and the substrate can be filled using intumescent acrylic material.
9. Ensure that any obstructions, which may have been temporarily moved, are refitted into place.



# SOIL & WASTE SYSTEMS

## SOIL SYSTEM TESTING

Source BS EN 12056-2:2000

National Annex NG (Informative) Inspection, testing and maintenance of completed installations

### NG.1 General

This annex provides information on testing methods and maintenance of above ground gravity sanitary pipework and fittings. This document covers domestic, commercial and public buildings, with the exception of trade waste discharges and any special requirements of building such as hospitals or research laboratories.

Inspections and tests should be made during the installation of the discharge system as the work progresses to ensure that the pipework is properly secured and clear of obstruction, debris and superfluous matter and that all work which is to be concealed is free from defects before it is finally enclosed.

Prefabricated units should be tested at the works or place of fabrication and inspected upon delivery to site.

### NG.2 Final Inspection

On completion, the discharge system should be meticulously inspected to ensure that the recommendations of this British Standard have been observed and that no cement droppings, rubble or other objects are left in or on the pipes and that no jointing material projects into the pipe bore. When this has been done, tests for the soundness of the pipework and for the performance should be made.

## NG.3 TESTING

### NG.3.1 Air Test

*NOTE Normally this test is carried out to confirm that all pipes and fittings are airtight. It should be completed in one operation but for large multi-storey systems testing in sections may be necessary*

#### NG.3.1.1 Preparation

The water seals of sanitary appliances should be fully charged and test plugs or bags inserted into the open ends of the pipework to be tested. To ensure that there is a satisfactory air seal at the base of the stack, or at the lowest plug or bag in the stack if only a section of the pipework is to be tested, a small quantity of water sufficient to cover the plug or bag can be allowed to enter the system.

One of the remaining test plugs should be fitted with a tee piece, with a cock on each branch, and one branch being connected by means of a flexible tube to a manometer. Alternatively, a flexible tube from a tee piece fitted with cocks on its other two branches can be passed through the water seal of a sanitary appliance. Any water trapped in this tube should be removed and then a manometer can be connected to one of the branches.

#### NG.3.1.2 Application

Air is pumped into the system through the other branch of the tee piece until a pressure equal to 38mm water gauge is obtained. The air inlet cock is then closed and pressure in the system should remain constant for a period of not less than 3 mins.

### NG.3.1.3 Leak location

*NOTE Defects revealed by an air test may be located by the methods given in NG.3.1.3.1, NG.3.1.3.2 and NG.3.1.3.3*

#### NG 3.1.3.1 Smoke

A smoke producing machine may be used which will introduce smoke under any pressure into the defective pipework. Leakage may be observed as the smoke escapes. Smoke cartridges containing special chemicals should be used with caution, taking care that the ignited cartridge is not in direct contact with the pipework and that the products of combustion do not have a harmful effect upon the materials used for the discharge pipe system.

Smoke testing of plastics pipework should be avoided due to naphtha having a detrimental effect, particularly on ABS, PVC-U and MUPVC. Rubber jointing components can also be adversely affected.

#### NG.3.1.3.2 Soap solution

With the pipework subject to an internal pressure using the smoke machine method as described in NG.3.1.3.1, a soap solution can be applied to the pipes and joints. Leakage can be detected by the formation of bubbles.

#### NG.3.1.3.3 Water test

There is no justification for a water test to be applied to the whole of the plumbing system. The part of the system mainly at risk is that below the lowest sanitary appliance, and this may be tested by inserting a test plug in the lower end of the pipe and filling the pipe with water up to the flood level of the lowest sanitary appliance, provided that the static head does not exceed 6m.

## NG.3.2 PERFORMANCE TESTS

### NG.3.2.1 General

All appliances, whether discharged singly or in groups, should drain speedily, quietly and completely.

To ensure that adequate water seals are retained during peak working conditions, the tests described in NG.3.2.2 should be carried out. After each test, a minimum of 25mm of water seal should be retained in every trap. Each test should be repeated at least three times, the trap or traps being recharged before each test. The maximum loss of seal in any one test, measured by a dip stick or small diameter transparent tube, should be taken as the significant result.

#### NG.3.2.2 Tests for self-siphonage and induced siphonage in branch discharge pipes

To test for the effect of self siphonage, the appliance should be filled to overflowing level and discharged by removing the plug; WC pans should be flushed. The seal remaining in the trap should be measured when the discharge has finished. Ranges of appliances, connected to a common discharge pipe, should also be tested for induced siphonage in a similar way.



# TRAPS



## TRAPS

Traps are an integral part of any waste system and are generally situated on the outlet of an appliance (to which the waste is attached).

The purpose of a waste trap is to provide a water seal between the waste water pipework and the internal environment of the property, thus stopping any foul air entering the building which would be both hazardous and unpleasant.

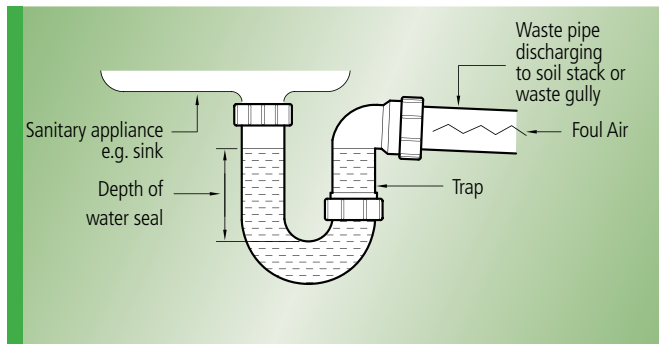

All points of discharge into a soil and ventilation system should be fitted with a trap to prevent foul air from the underground drainage system entering the building. Under working and test conditions, traps should retain a minimum water seal of 25mm.

If a trap forms part of an appliance, e.g. a wc, the appliance should be removable. All other traps should be fitted directly after the appliance and should be removable or be fitted with a cleaning eye.

The depth of water seal is the vertical distance between the water level in the trap after discharge and the point at which the water would be at such a level as to allow foul air through the trap (see diagram above).



Minimum diameters and depth of seals for waste traps are specified in the Building Regulations and are shown in the table 6 below :-

TABLE 6: MIN DIMENSIONS OF TRAPS AND WATER SEALS

Appliance	* Diameter of trap (mm)	Depth of water seal (mm)
Washbasin	32	75
Bidet	32	75
Bath	40	50
Shower	40	75
Sink	40	75
Washing machine	40	75
Dishwasher	40	75
Waste disposal unit	40	75
Urinal Bowl	40	75

\* Diameter of traps indicated refers to the nominal inside diameter of the waste pipework to which they are fitted.

Where baths, showers, washing machines and dishwashers discharge directly to a gully, the depth of seal may be reduced to 38mm.

### Joining to waste pipes

Most traps available in the UK have universal compression outlets and will connect onto push-fit and solvent weld plastics waste systems together with imperial and metric copper systems.

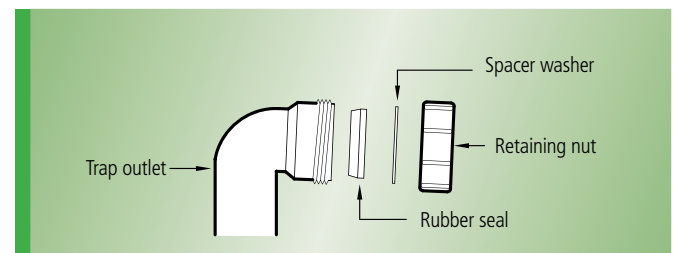

# TRAPS



## TYPES OF TRAP

### Tubular Trap

There are two forms of Tubular Trap, a "P" Trap for horizontal outlets and an "S" Trap for vertical outlets. Tubular traps usually have a nut which can be loosened, allowing the outlet to be rotated around to the required direction and which is then re-tightened.

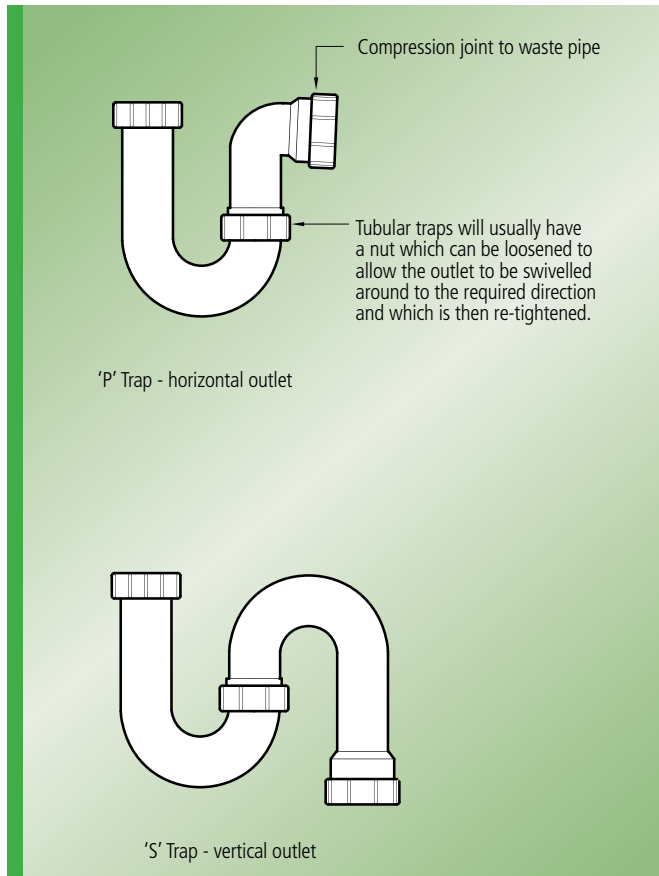

### Pedestal Trap

Pedestal Traps are also known as Straight Through Traps or Bag Traps and are generally used in instances where there is insufficient space to install a standard bottle or Tubular Trap.

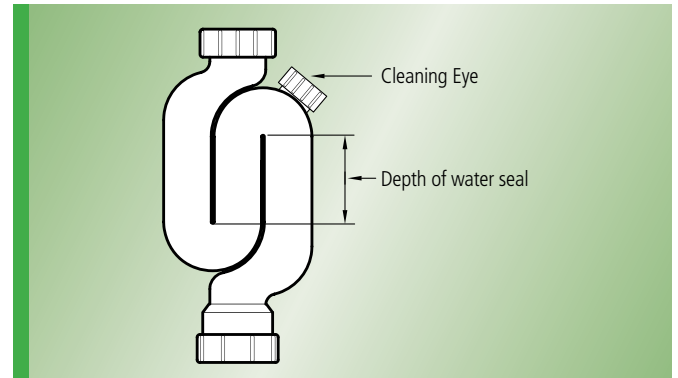

### Washing Machine Traps

Traps designed for washing machines are typically similar to tubular traps and must cater for the connection of the flexible hose running from the appliance.

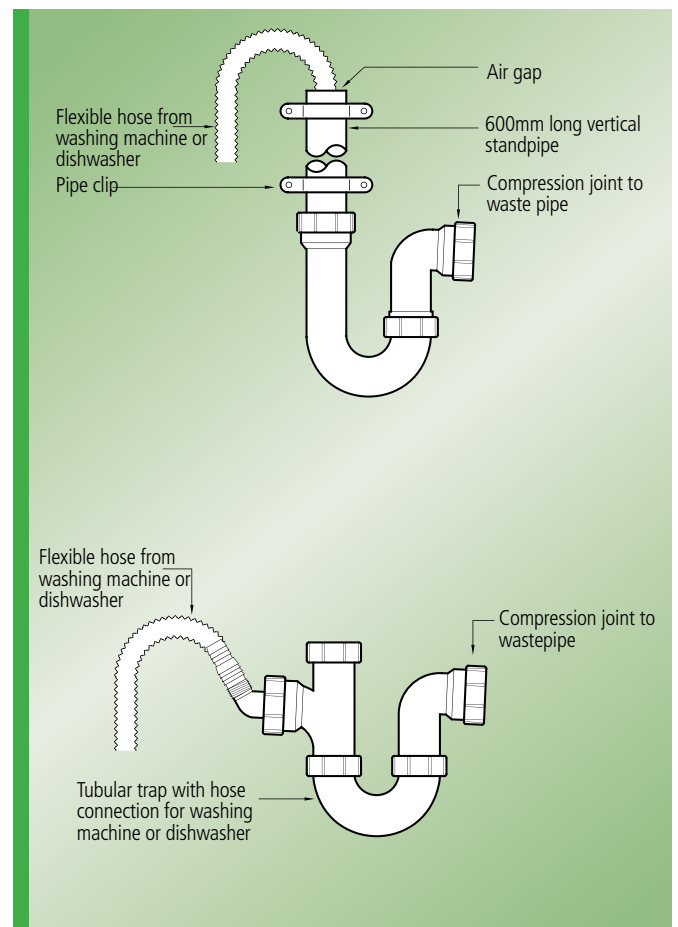

### Bottle Trap

Bottle Traps have a central vane, or dip tube to form the trap. There is a removable bowl to clear any blockages. This form of trap should only be used on washbasins.

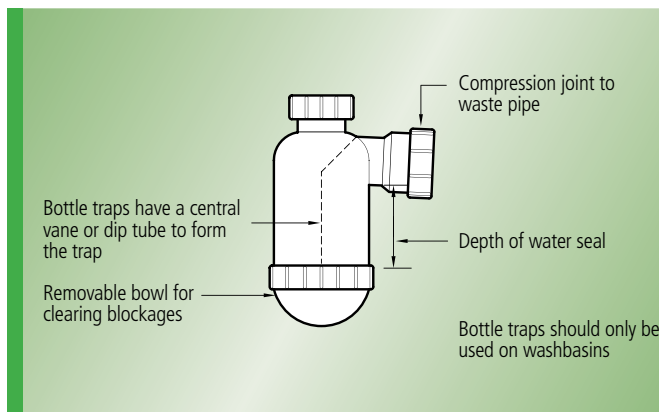

# TRAPS



## TYPES OF TRAP continued

### Undersink Kits

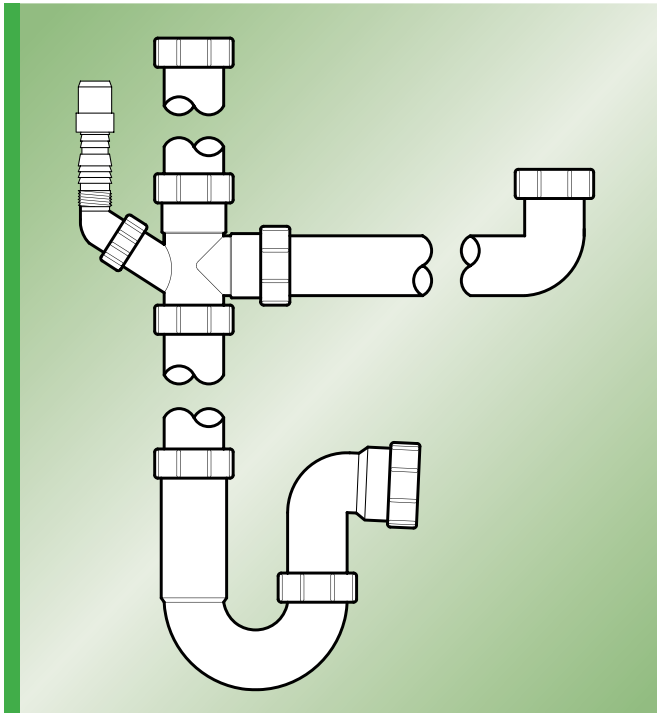

This type of trap arrangement is used in situations where there may be a double bowl or bowl and a half unit and where a washing machine needs to be connected. Polypipe offer a wide variety of trap configurations to suit most requirements.



### Resealing and Anti-Siphon Traps

Resealing and Anti-Siphon traps are used generally for the same purpose, that is to prevent the loss of the water seal in the trap due to either self or induced siphonage. The diagrams below show how each of the traps work.

#### Resealing Trap

When the trap is subject to siphonic action water is pulled through the trap until it reaches the air break in the dip tube where the siphonic action is broken. The remaining water in the trap falls back into place and reforms the water seal.

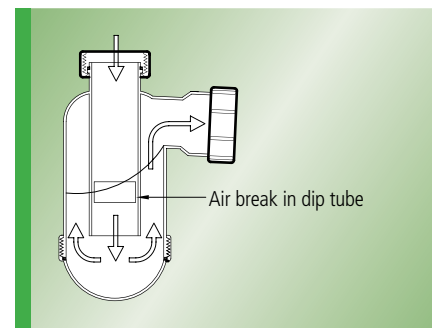

#### Anti-Syphon Trap

When the trap is subject to siphonic action, the negative pressure in the system results in a one way valve on the trap outlet opening, allowing air into the system and thus preventing a loss of the water seal. When the siphonic action ceases, the valve will close and remain airtight preventing foul air escaping into the room.

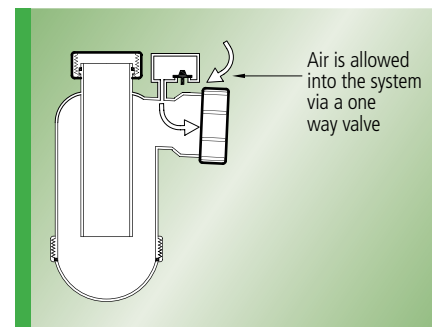

# RAINWATER SYSTEMS



## GUTTER AND DOWNPIPE SYSTEMS

A comprehensive range of fittings accompanies each rainwater profile in Polypipes unrivalled product range, to provide the specifier and installer with a complete roof drainage solution.

As part of our continued product development initiatives we are constantly introducing new products and updating our existing ranges, hence our rainwater range now incorporates nine different systems to cover all installations from domestic and commercial to industrial.

These nine systems provide a variety of profiles and capacities ensuring that every installation is catered for whether it is a modern streamline dwelling (Sovereign) or an industrial property (150mm half round).

All rainwater products are manufactured from PVCu in accordance with a Quality Management System to BS EN ISO 9001 (certificate no FM00318).

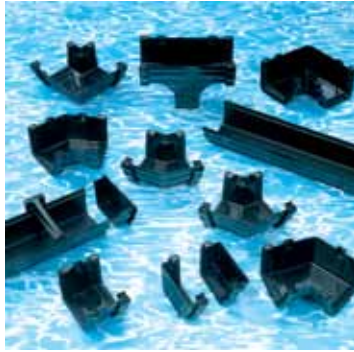

### PROFILES AVAILABLE:

19 / 39.1cm <sup>2</sup>	52.7cm <sup>2</sup>	57.1cm <sup>2</sup>
75mm & 112mm Half Round	112mm Square	117 x 75mm Polyflow
57.8cm <sup>2</sup>	84.6cm <sup>2</sup>	70cm <sup>2</sup>
130mm x 70mm Ogee	150mm Industrial HR	117 x 75mm Sovereign

112mm Half Round and Notched Ogee are available in the Elegance Cast Iron Effect Rainwater System.

TABLE 7: PRODUCT COMPATIBILITY CHART

Gutter Size	75mm Half Round	112mm Half Round	112mm Square	117x75mm Polyflow	130x70mm Ogee	117x75mm Sovereign	150mm Half Round
Downpipe Size	50mm Round	68mm Round	65mm Square	68mm Round	68mm Round 65mm Square	68mm Round 65mm Square	110mm
Hepworth	No	Yes	Yes	No	No	No	Yes
Osma	No	Yes	No	No	No	No	Yes
Hunter	No	Yes	Yes	No	No	No	No
Marley	Yes	Yes (clipmaster)	No	No	No	No	Yes
Brett Martin	No	Yes	Yes	No	No	No	No
Floplast	No	Yes	Yes	No	No	No	No
Marshall Tufflex	No	Yes	Yes	No	No	No	Yes
Freefoam	No	Yes	No	No	No	No	No

TABLE 8: COLOUR AVAILABILITY

Polypipe Gutter	75mm Half Round	112mm Half Round	112mm Square	117x75mm Polyflow	130x70mm Ogee	117x75mm Sovereign	150mm Half Round
Black	Yes	Yes	Yes	Yes	Yes	Yes	Yes
Brown	No	Yes	Yes	Yes	Yes	Yes	Yes
Grey	Yes	Yes	No	Yes	No	No	Yes
White	Yes	Yes	Yes	Yes	Yes	Yes	No
Oak Brown	No	No	No	No	No	Yes	No
Cast Iron Effect	No	Yes	No	No	Yes	No	No



# RAINWATER SYSTEMS



## HANDLING AND STORAGE

Although rainwater gutter, downpipe and the associated fittings are strong and lightweight, care must be taken when handling.

Extra precaution should be taken in cold conditions due to the reduction in impact strength of plastic products.

All gutter and downpipe extrusions should be stored away from direct sunlight and preferably under cover. When stored in any form of racking all extrusions should be supported at no more than two metre intervals.

Fittings should be kept under cover in their respective packaging until such time as required for installation.

Solvent cement should also be kept out of direct sunlight or away from any other heat source.

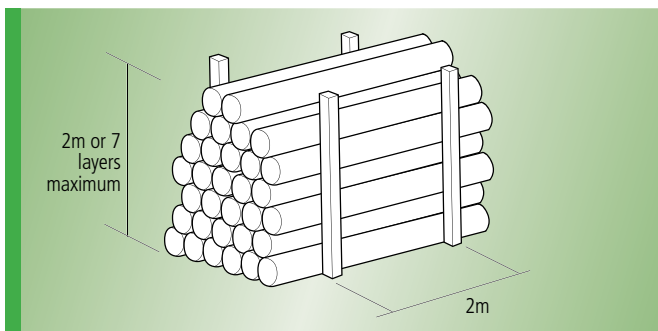

## CALCULATING ROOF AREAS

The aim of designing a rainwater system is normally to achieve a balance between the cost of the system and the frequency and consequence of possible flooding. The capacity of the gutter should be sufficient to provide adequate disposal of the heavy rainfall usually associated with summer thunderstorms.

A simple methodology for roof drainage design is shown below but for further information regarding roof drainage refer to BS EN 12056-3: 2000 Roof Drainage, Layout and Calculation.

### Calculate the Effective Roof Area (E.R.A.)

To calculate the effective roof area use the following equation:

$$\text{E.R.A. (m}^2\text{)} = \left( \frac{H}{2} + W \right) \times L$$

Where:

H=Height of pitch roof

W=Width of pitch roof

L=Length of roof

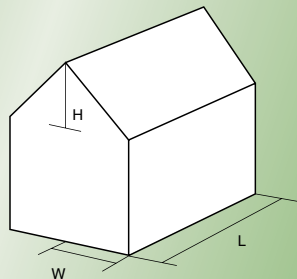

**Where the pitch of the roof is of an angle of less than 10% the effective roof area is simply the plan area of the roof i.e. length (L) x width (W).**

## GUTTER SELECTION

Due to the infrequency of extremely heavy rainfall in the United Kingdom, it is almost impossible to design a cost efficient rainwater system to give complete immunity from flooding and overflow.

Because of this it is generally regarded as normal practice to design rainwater systems using a rainwater intensity level of 75mm per hour. To calculate the gutter requirement, multiply the E.R.A. (m<sup>2</sup>) by a factor of 0.0208 (75mm/hour divided by 3600 seconds/hour) to give the flow rate in litres/second (l/s).

Once a flow rate has been determined use tables 9 & 10 opposite to select the required gutter profile.

**Note:** If a gutter angle is introduced into the rainwater gutter run, the effective gutter capacity will be affected and an adjustment must be made to the maximum roof area which each rainwater system is capable of draining (see Code of Practice BS EN 12056-3:2000 for further details).

To calculate the revised maximum roof area which can be drained when the gutter run contains an angle the following factors must be applied to the figures in tables 9 and 10 opposite.

Level gutter run with angle within 2 metres of outlet	<b>10% reduction</b>
Level gutter run with angle further away than 2 metres of outlet	<b>5% reduction</b>
Gutter run at 1:600 fall with angle within 2 metres of outlet	<b>20% reduction</b>
Gutter run at 1:600 fall with angle further away than 2 metres of outlet	<b>10% reduction</b>

# RAINWATER SYSTEMS



TABLE 9: GUTTER FLOW CAPACITY BASED ON LEVEL FALL

Outlet fixed at	Flow Capacity (l/s)		Maximum Roof Area (m <sup>2</sup> )	
	End	Centre	End	Centre
75mm - Half Round	0.390	0.680	16	32
112mm - Half Round	0.912	1.833	44	88
112mm Square	1.083	2.167	52	104
Polyflow - Deep Capacity	1.800	3.600	86	172
Ogee	1.833	3.667	88	176
Sovereign	2.100	4.200	101	202
150mm - Half Round	2.300	4.600	110	220

TABLE 10: GUTTER FLOW CAPACITY BASED ON 1:600 FALL

Outlet fixed at	Flow Capacity (l/s)		Maximum Roof Area (m <sup>2</sup> )	
	End	Centre	End	Centre
75mm - Half Round	0.520	0.900	24	48
112mm - Half Round	1.300	2.600	62	124
112mm Square	1.517	3.033	72	144
Polyflow - Deep Capacity	2.500	5.000	120	240
Ogee	2.567	5.133	123	246
Sovereign	2.950	5.900	142	284
150mm - Half Round	3.233	6.467	154	308

## JOINTING BRACKETS AND SUPPORTS

### 1. Preparing gutters & pipes

All rainwater gutters and pipes must be squarely cut and all burrs must be removed. It is recommended that a fine toothed handsaw is used. Care must be taken when cutting gutters and pipes in cold or damp conditions due to the slippery nature of the pipe surface.

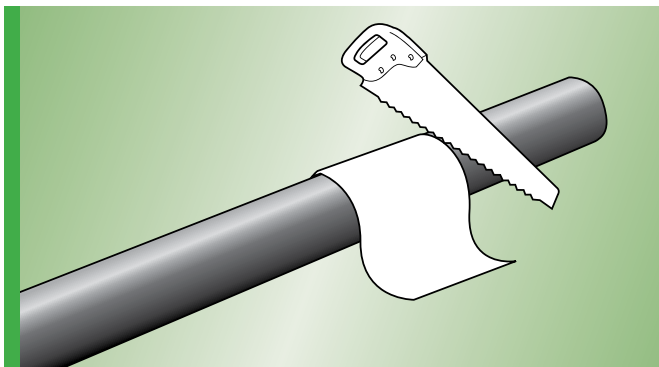

### 2. Gutter position

All gutters should be installed as high as possible and be positioned so that the edge of the roof is central to the cross section of the profile.

Although the performance of Polypipe gutter profiles enables them to be installed level it is recommended that a fall of 1:600 is achieved. Supporting at the recommended spacings (see table 11 below) will reduce any sort of ponding, sagging or silting.

TABLE 11 - GUTTER SUPPORT CENTRES

Profile	Max support centres
75mm - Half Round	0.5 metres
112mm - Half Round	1 metre
112mm Square	1 metre
Polyflow	1 metre
Overflow	1 metre
Sovereign	1 metre
150mm - Half Round	1 metre

# RAINWATER SYSTEMS



## 3. Brackets and supports - general

Due to the varied nature of rainwater installations Polypipe offers a wide range of support options for its gutter profiles.

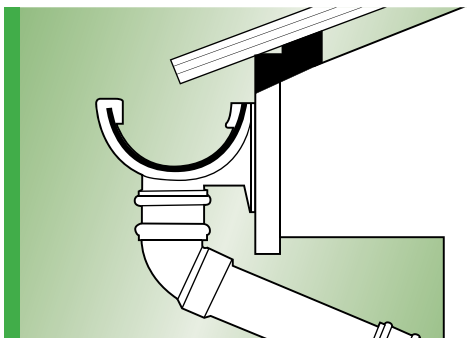

All systems feature a standard PVCu fascia bracket as well as top and side rafter brackets and rise and fall brackets in galvanised metal. Also included in the range are top and side universal rafter arms for use with all Polypipe gutter fascia brackets (except 150mm half round) gutter unions and running outlets.

As part of the Sovereign and Ogee ranges, a top hang fascia bracket which provides further enhancement of the gutter profile whilst giving support which is virtually invisible from ground level.

All supports should be fixed at centres not exceeding those detailed in table 11 on page 23 as well as adjacent to both ends of any gutter angles.

It is recommended that the bracket furthest away from the downpipe outlet is installed first. This means that if a fall is applied to the gutter this will be the highest bracket installed, therefore the correct gutter height will be determined immediately as installation commences.

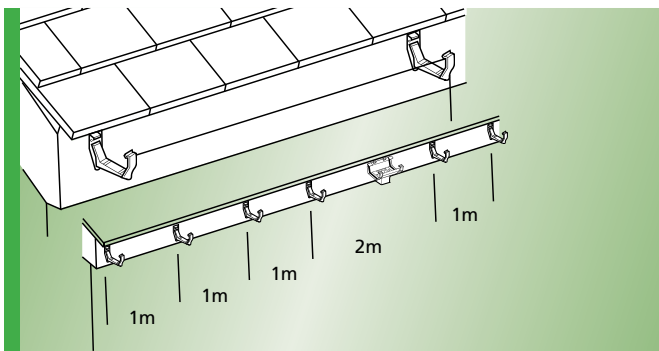

### Fascia Brackets

All Polypipe gutter fascia brackets incorporate three screw holes, under normal circumstances it is only necessary to use the centre fixing hole but it is recommended that all three are utilised in order to counter the effects of heavy snow fall or high winds. It is also recommended that support centres are reduced in situations where such heavy snow fall or high winds are common.

For more information visit the website [www.polypipe.com/bp](http://www.polypipe.com/bp), click on Literature Downloads link and see "Rainwater Systems and Snowloading"

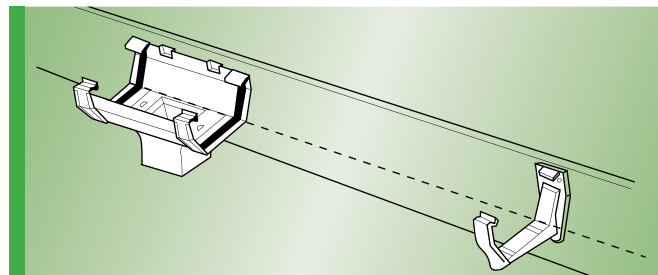

All components should be secured to the fascia using corrosion resistant No.10 roundhead screws.

Normally traditional techniques are used when installing fascia brackets i.e. using a plumb line along the length of the fascia board and fixing brackets at intervals as shown in table 11 on page 23.

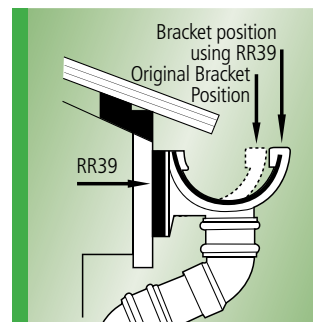

If there is excessive overhang from the roof tiles then it is possible to use a spacer plate (RR39) to bring the gutter forward by 15mm. This may prevent the need for a wider profile gutter. In this instance spacer plates should be used behind all fascia brackets, unions and outlets.

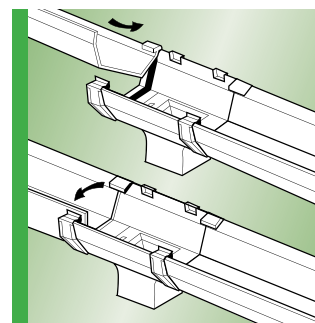

Necessary space must be left between support brackets for any unions or outlets. Unions and outlets must be secured to the fascia utilising the screw holes provided on each fitting.

Once all brackets, unions and outlets are in place the gutter can then be clipped into place.

All Polypipe rainwater systems use a flexible clipping band to secure the gutter profile providing a sound watertight joint.

There is no need to remove the clipping band to complete the installation. The gutter is simply offered into the bracket, union or outlet with the side nearest the fascia being introduced first. Then by applying a little downward pressure to the gutter the clipping band is pushed over the top edge of the gutter.

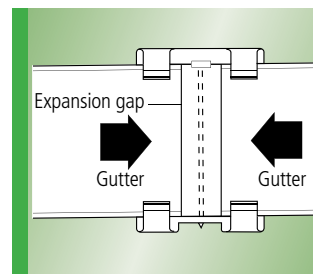

On all gutter joints an expansion gap must be allowed to ensure that any thermal movement is accommodated between two fixed gutter fittings.

# RAINWATER SYSTEMS



Insertion depths are marked on all Jointing fittings, such that, if the gutter ends are fitted to the "insert to here" lines there will be ample provision for expansion and contraction under normal UK conditions.

It is recommended that external stop ends should only be used where the gutter length from the running outlet does not exceed 300mm.

Where gutter lengths exceed 300mm, a fixed union bracket and an internal stop end should be used to ensure that expansion and contraction is controlled.

## Top Hanging Brackets

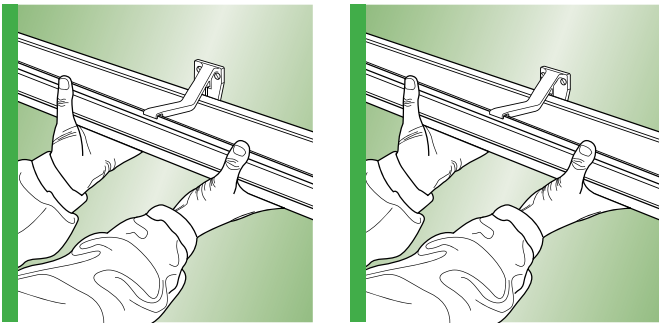

In addition to the standard fascia bracket the Sovereign and Ogee ranges also incorporate top hang brackets. An angled top hang bracket is available for use with conservatories in the Sovereign Range. The method of fixing the brackets to the fascia is exactly the same as the standard fascia bracket.

The front edge of the gutter should be clipped into the bracket and then the back edge of the gutter should be snap fitted into place by applying upward pressure, the profile will clip into place providing a robust support with aesthetic advantages.

The conservatory style bracket is fixed in exactly the same manner as the top hang bracket but incorporates an "V" section so the roof of the conservatory does not interfere with the bracket when fixed in position.

## Rafter Brackets

In addition to the range of fascia brackets Polypipe offer a range of rafter brackets to suit each gutter profile.

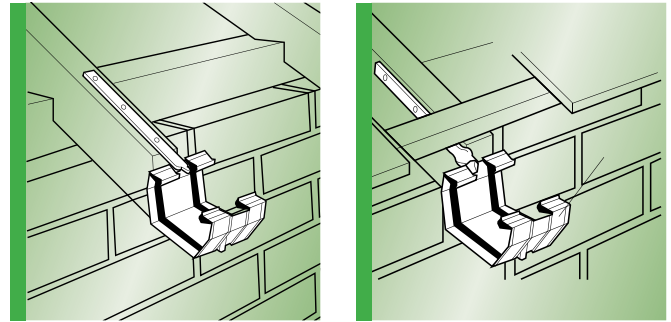

Rafter brackets can be used where there is no fascia board in place to fix a bracket to. They are screwed to the rafters either before the roof is fixed in place (top rafter bracket) or after the roof is completed (side rafter bracket). Side rafter brackets are ideal for maintenance work as they can be installed with the roof in place.

Standard Rafter Brackets only fit around gutter, not fittings. It is necessary to use the Universal Rafter Brackets to connect Unions and Running Outlets.

Universal rafter arms are suitable for all Polypipe fascia brackets other than the 150mm half round system.

All rafter brackets are galvanised metal therefore corrosion resistant.

When using rafter type brackets all gutter joints must be made using gutter union brackets / universal rafter brackets or, alternatively, supports should also be fixed either side of each fitting in any gutter run.

Should a gradient be required in the gutter run then rise and fall brackets can be used as an alternative to the rafter brackets where there is no fascia board in place.

If the installer wishes he can also use the universal rafter arm in combination with a standard fascia bracket to include a fall.

These are available in top and side variations and allow for up to 65mm height adjustment.



# RAINWATER SYSTEMS



## DOWNPIPE INSTALLATION

It is recommended that all downpipes are solvent welded to the running outlets to prevent any dropping of downpipes due to the thermal expansion of the plastic pipe system. 10mm expansion gaps must be left between the end of the downpipe and the bottom of the sockets of all other fittings in the downpipe run.

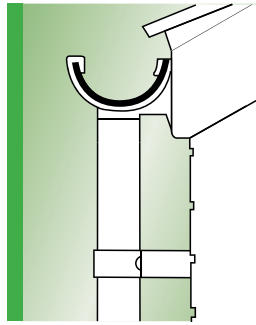

As with gutter runs all downpipe runs must be securely supported. Support centres are shown in the table below.

Additional to the supports required by table 12 all offsets, connectors, shoes and access pipes should be securely supported.

TABLE 12: DOWNPIPE SUPPORT CENTRES

Pipe Size	Max support centres	Max support centres
	Horizontal runs	Vertical runs
50mm Round	1.0 metre	1.0 metre
68mm Round	1.0 metre	2.0 metres
65mm Square	1.0 metre	2.0 metres
110mm Round	0.9 metre	1.8 metres

### Outlets and Offsets

All Polypipe downpipes will connect directly on to the spigot of a running outlet.

Due to building design it is usually not possible to connect a downpipe to the outlet and continue this to the drain connection without any joints. An offset is often required at the gutter outlet.

All offsets at roof line level are achieved by using the offset bends detailed in the current trade price list.

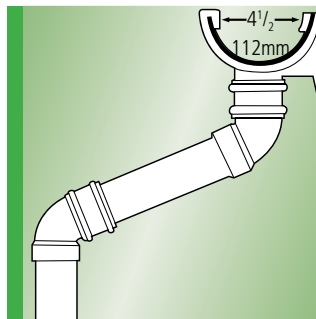

65mm square and 68mm circular are available in both 92.5° and 112.5° angles 50mm is available in 112.5° angle only. To give the offset joints a clean look the RR 136 joint cover is available for the 68mm round downpipe system.

All offsets should be supported directly beneath the lower offset bend by a pipe bracket or clip. In the case of 65mm square downpipes the RS233 / RS234 connector.

Should there be a case where the downpipe needs to stand off the wall slightly, i.e. offset decorative brickwork or tudor style beams, then a downpipe spacer (PA20) can be used to give an extra 30mm clearance between the downpipe and the wall.

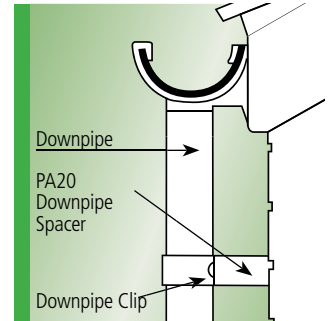

For connections to drains including rainwater shoes and adaptors see Connections to Drainage Systems section.

## CONNECTION TO OTHER MATERIALS

As part of the half round, square and ogee ranges Polypipe supply a range of gutter adaptors to connect to existing metal profiles. These include connections to half round, square and both left and right hand ogee profiles.

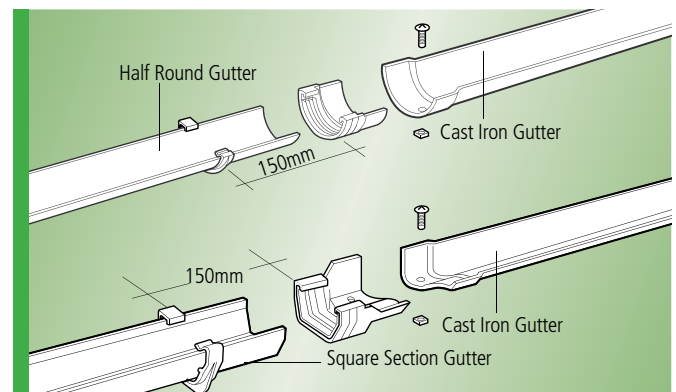

Connection to the metal gutter is made by installing a bolt through both the adaptor and the metal gutter section and sealing the joint with an appropriate waterproof mastic.

All adaptors must be supported at either side of the connection.

# RAINWATER SYSTEMS



## CONNECTION TO DRAINAGE SYSTEMS

There are various different ways of connecting the rainwater downpipe to the drainage system.

This can be achieved in two basic methods.

Terminating the downpipe with a rainwater shoe for disposal into a hopper or gully or connection directly to the underground drainage system using a rainwater pipe adaptor.

### Rainwater Shoe discharging over Square Hopper

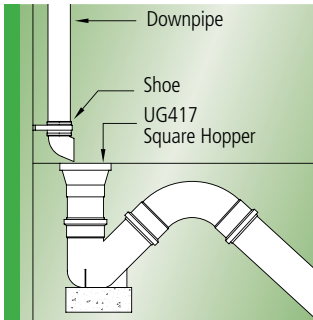

### Downpipe discharging into Bottle Gully

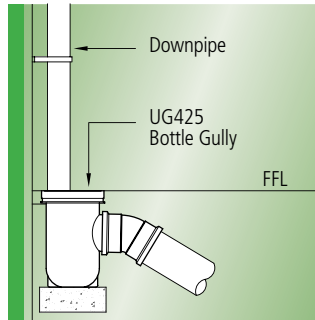

### Downpipe discharging into Rainwater to U/G Pipe Adaptor

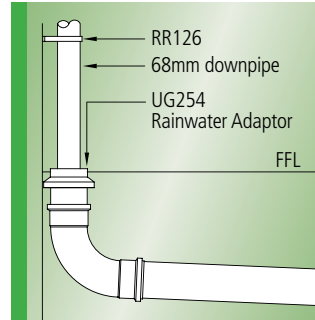

### Square Downpipe discharging into drain via square to round Adaptor

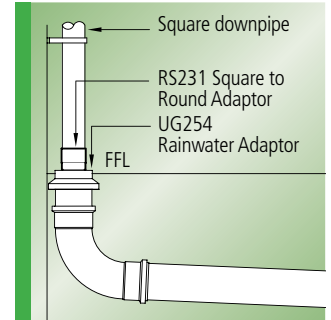

### Downpipe discharging into Universal Drain Adaptor

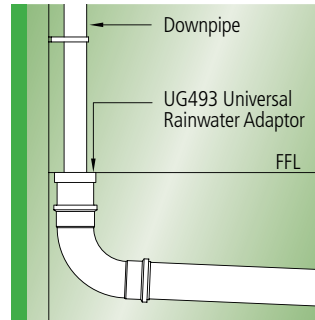



# BELOW GROUND DRAINAGE

Polypipe's Below Ground proposition is not confined purely to drainage products. The range of below ground drainage fittings and pipes is impressive. As well as a significant range of traditional underground drainage pipe, fittings and chambers, we can also provide structured wall sewer systems (see Polysewer on page 42) and a comprehensive offering of Civils products such as Rainstream Rainwater Harvesting tanks and Polystorm modular water storage.

All Polypipe's Above and Below Ground product offering can be found in the current Trade Price list, available to download from our website:

[www.polypipe.com/bp](http://www.polypipe.com/bp)







## BELOW GROUND SYSTEMS

28 - 42

### Introduction

28 - 29

Certificates and Approvals

3

### Drainage

30 - 38

Dimensions and Weights

30

Methods of Jointing

30

Calculation of Flow Rates

31

Capacities of Drains

32

Bedding and Backfilling

33

Protection for Pipes

34

Pipes laid at shallow depths under buildings

34

Pipes near buildings

35

Joint for concrete encased pipe

35

Pipes through walls

35

Connection Details

36 - 37

(Soil Pipes, Gullies, Rodding Eyes, Waste Pipes etc)

Yard Gully Detail

38

Road Gully Detail

38

### Inspection Chambers

39 - 41

Design Requirements

39

Inspection Chambers

39 - 41

(including Design Requirements, Chamber Depths, Joint Risers, Cover & Frames & Covers for Internal Use)

### Testing Below Ground Drainage

41

### Polysewer

42





# BELOW GROUND DRAINAGE

## DIMENSIONS & WEIGHTS

TABLE 13: BELOW GROUND DRAINAGE DIMENSIONS & WEIGHTS

Product	Outside Diameter (mm) Min	Wall Thickness (mm) Min	Weight Per Metre (kg) min
82mm Underground Drain	82.40	3.20	1.18
110mm Underground Drain EN 140 1-1	110.00	3.20	1.59
160mm Underground Drain EN1401-1	160.00	4.10	2.97
200mm Sewerdrain EN1401-1	200.00	4.90	4.44
250mm Sewerdrain EN1401-1	250.00	6.10	6.92
315mm Sewerdrain EN1401-1	315.00	7.70	11.00
150mm Polysewer WIS 4-35-01	160.00	7.00	1.70
250mm Polysewer WIS 4-35-01	250.00	10.50	3.80
300mm Polysewer WIS 4-35-01	330.00	14.50	6.30

## METHODS OF JOINTING

### PUSH-FIT (Ring Seal) JOINTING

- Where plain end pipe is being used, ensure that the pipe is cut square to its axis and that all burrs are removed.
- Chamfer the end of the pipe to prevent the ring seal being damaged or displaced when the pipe is inserted into the socket. Fittings with spigot ends are moulded with a chamfer during manufacture.
- Lubricate the spigot or ring seal with silicone grease or aerosol lubricant.
- Insert the pipe or fitting into the socket and then withdraw it by approx. 10mm to allow for expansion of the pipework.

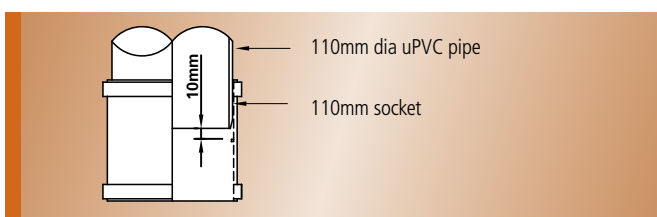

### SOLVENT WELD JOINTING

- Ensure that the pipe is cut square and that all burrs are removed.
- Ensure that both surfaces to be jointed are dry and free from dust or other debris.
- Use Polypipe cleaning fluid CF250 to remove any surface grease from the spigot and socket to be jointed.
- Apply a coat of Polypipe solvent cement to both surfaces to be jointed using the brush applicator provided in the lid. The cement should be applied along the length of the spigot and not around its diameter.
- The spigot should be inserted into the socket immediately, with a slight twisting action.
- Any surplus solvent cement should be removed with a clean cloth.
- The joint will be strong enough to handle after approx. 5 minutes and can be tested after 12 hours.

The following table indicates the approximate number of joints that can be made for each pipe diameter with solvent cement, cleaning fluid and silicone grease.

TABLE 14: SOLVENT WELD JOINTS

Product	Number of Joints		
	82mm	110mm	160mm
Solvent Cement 125ml Code SC125	9	5	3
Solvent Cement 250ml Code SC250	18	10	6
Solvent Cement 500ml Code SC500	35	20	12
Cleaning Fluid 250ml Code CF250	30	20	15
Silicone Grease 100gm Code SG100	35	20	10



# BELOW GROUND DRAINAGE

## CALCULATION OF FLOW RATES

### Foul Drains

Individual sanitary appliances, e.g. a WC or washbasin have a Discharge Unit value to enable flow rates to be established. BS EN 12056-2: 2000 details the Discharge Unit values, which may vary slightly, depending on the soil system configuration to which they are connected. However, the following figures are suitable for general calculation purposes.

TABLE 15: DISCHARGE UNIT VALUES

Appliance	Discharge Unit Value
Washbasin	0.5
Bidet	0.5
Shower	0.6
Single urinal with cistern	0.8
Bath	0.8
Sink	0.8
Dishwasher	0.8
Washing machine	0.8
WC with 7.5 litre cistern	2.0

Formula for calculation of flow rate:  $Q = k \sqrt{\sum DU}$

Where:  $Q =$  Flow Rate in litres/sec

$k =$  Frequency factor

$\sum DU =$  Sum of discharge units

$k =$  0.5 for dwellings, guest houses, offices etc.

0.7 for hospitals, schools, restaurants, hotels etc.

1.0 for toilets/showers open to the public.

### Surface Water Drains

It is generally accepted that a suitable rainfall design intensity for sizing surface water drains is 0.014 litres/second/m<sup>2</sup> (50mm/hour).

For high risk areas, where ponding would lead to flooding of buildings, the drainage scheme should be designed in accordance with BS EN 752:part 4, where a higher rainfall intensity would be appropriate.

### Minimum Velocities

Flow velocities in drainage systems should be a minimum of 0.76 metres/sec to avoid the possibility of grit and other solid waste being deposited along the invert of the drain.

TABLE 16: MAXIMUM SPACINGS OF ACCESS POINTS

From	To	Junction	Inspection Chamber	Manhole
Start of external drain (stack or ground floor appliance)		-	22m	45m
Rodding Eye		22m	45m	45m
Shallow Inspection Chamber (up to 1.0m deep)		22m	45m	45m
Deep Inspection Chamber and Manhole (deeper than 1.0m)		-	45m	90m



# BELOW GROUND DRAINAGE

## CAPACITIES OF DRAINS

The capacity of a drainage system will be determined by the diameter and gradient of the pipework. The table shows capacities of 110mm and 160mm diameter drains for each of the roughness coefficient factors usually applied to pipework for calculation purposes as follows:

$k = 0.06$  for new surface water drains

$k = 0.60$  for new foul water drains

$k = 1.50$  for mature foul drains

The figures are also based on the recommended proportional depth of flow of 0.75. Foul drains are normally designed to carry peak discharges at less than full depth to allow for a safety factor and to aid ventilation.

TABLE 17: DRAIN CAPACITIES

Gradient 1 in...	110mm k= 0.06	110mm k=0.60	110mm k=1.50	160mm k=0.06	160mm k=0.60	160mm k=1.50
<b>Capacity in Litres/Second</b>						
5	33.3	25.1	21.6	96.2	73.4	63.5
10	23.3	17.7	15.3	67.4	51.8	44.9
15	18.9	14.5	12.4	54.7	42.2	36.6
20	16.3	12.5	10.8	47.2	36.5	31.6
25	14.5	11.2	9.7	42.0	32.6	28.4
30	13.0	10.2	8.8	38.2	29.8	25.9
35	12.2	9.5	8.2	35.3	27.5	23.9
40	11.3	8.8	7.6	33.0	25.9	22.0
45	10.5	8.3	7.2	31.0	24.1	21.0
50	10.0	7.8	6.7	29.2	23.0	20.0
55	9.5	7.5	6.5	28.0	22.0	19.0
60	9.2	7.2	6.2	26.7	21.0	18.0
65	8.6	6.8	5.8	25.4	20.1	17.5
70	8.5	6.6	5.6	24.6	19.4	16.8
75	8.0	6.4	5.5	23.8	18.8	16.3
80	7.8	6.2	5.3	23.0	18.0	15.7
85	7.5	6.0	5.2	22.2	17.5	15.1
90	7.3	5.8	5.0	21.7	17.0	15.4
95	7.1	5.7	4.9	21.0	16.6	14.2
100	6.9	5.5	4.8	20.5	16.2	14.0



# BELOW GROUND DRAINAGE

## BEDDING & BACKFILLING

### 1. Pipe laid on trench bottom

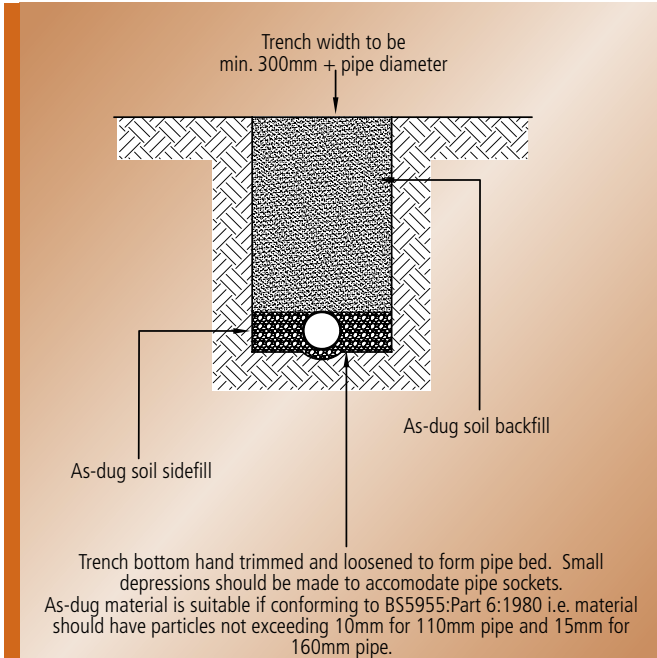

### 2. Pipes laid on 50mm granular bedding

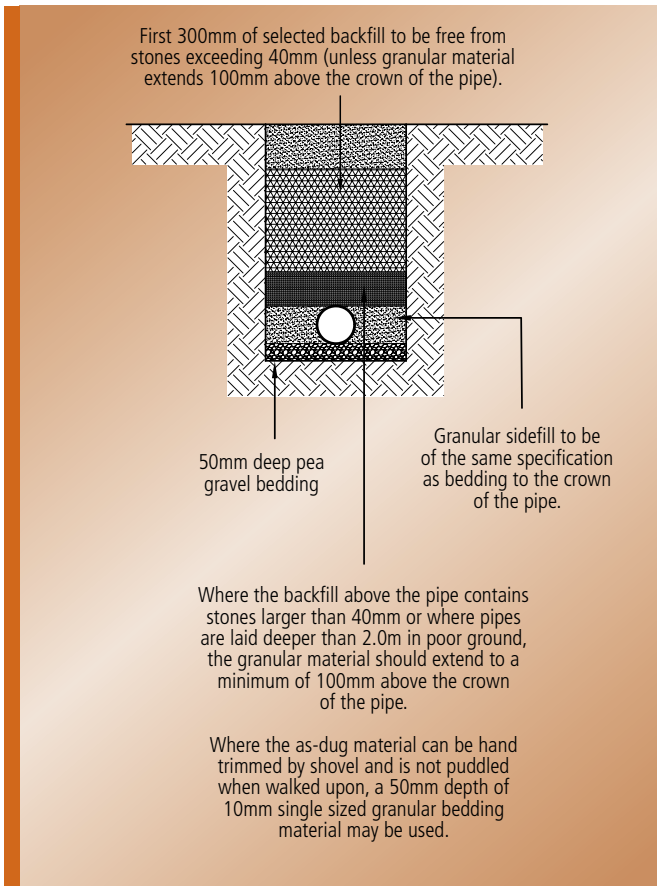

### 3. Pipes laid on 100mm granular bedding

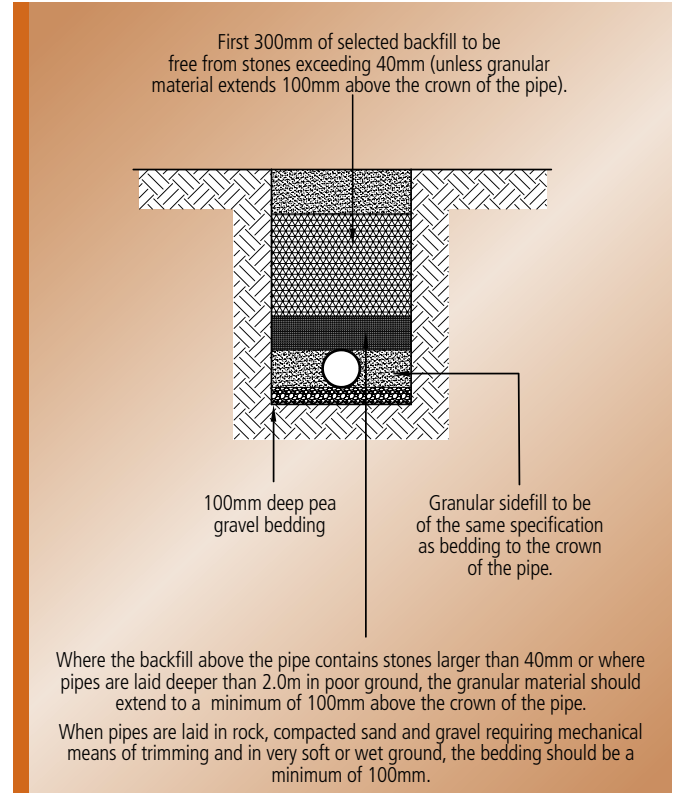
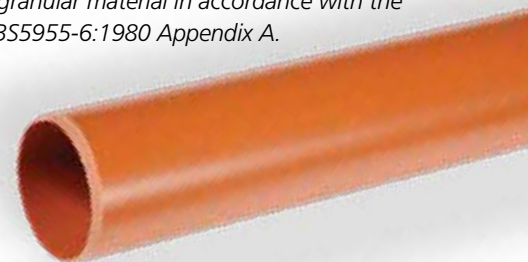

TABLE 18: GRANULAR BEDDING AND SIDEFILL MATERIALS FOR PVCu DRAINAGE PIPES

Pipe Dia	Nominal max. particle size	Material Detail
100mm	10mm	10mm single size with no sharp edges
Over 100mm to 150mm	15mm	10mm or 14mm single size or 14mm to 5mm graded
Over 150mm to 300mm	20mm	10mm, 14mm or 20mm single size or 14mm to 5mm graded or 20mm to 5mm graded

Note: Installation should be carried out in accordance with BS5955-6:1980 and BS EN 752-1 to 4.

Where the 'as dug' material is suitable as bedding, the bottom of the trench may be trimmed to form the pipe bed. Suitable material is defined as granular material in accordance with the recommendations of BS5955-6:1980 Appendix A.





# BELOW GROUND DRAINAGE

## PROTECTION FOR PIPES

### 1. Pipes laid at shallow depths in non-trafficked areas

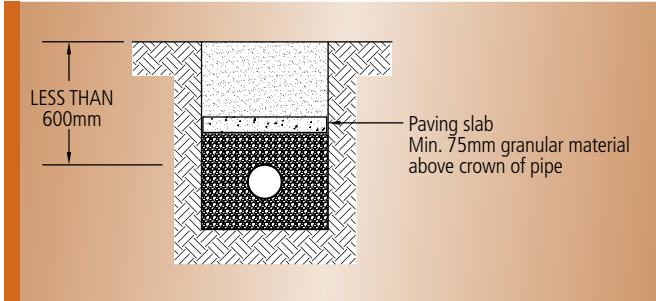

Pipes laid in non-trafficked areas, e.g. in gardens with less than 600mm of cover, should be protected against damage by placing paving slabs or similar over them across the whole width of the trench.

A layer of granular material of 75mm min thickness must be laid between pipes and slabs.

### 2. Pipes laid at shallow depths in adoptable trafficked areas

#### 2 (a)

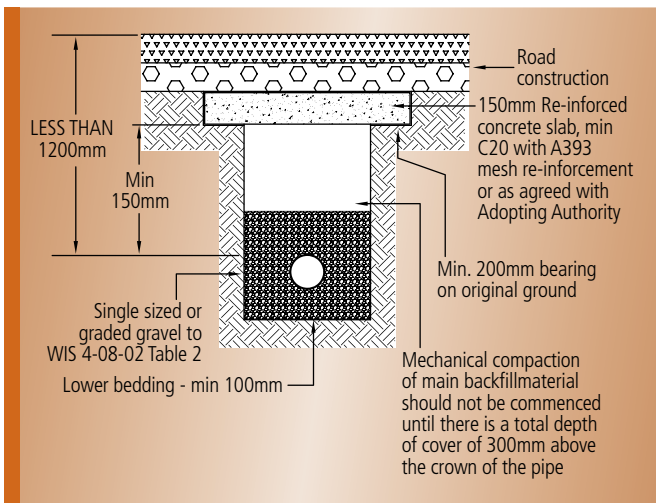

Sidefill material to be placed evenly on both sides of pipe, taking care to work the material under the lower quadrant of the pipe, ensuring the pipe is not lifted. Both sides of the trench should be filled simultaneously to avoid horizontal movement of the pipe.

#### 2 (b)

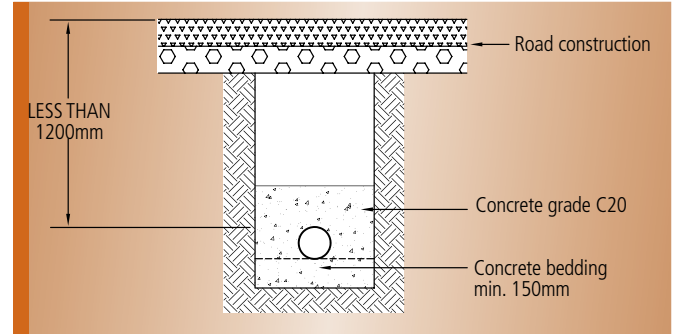

Flexible joints to be provided in concrete at each pipe joint. It is recommended that 3.0m pipe lengths are used where concrete encasement is required.

## PIPES LAID AT SHALLOW DEPTHS UNDER BUILDINGS

Where the crown of the pipe is within 300mm of the underside of the slab, the pipework should be surrounded with 150mm concrete as an integral part of the floor slab.

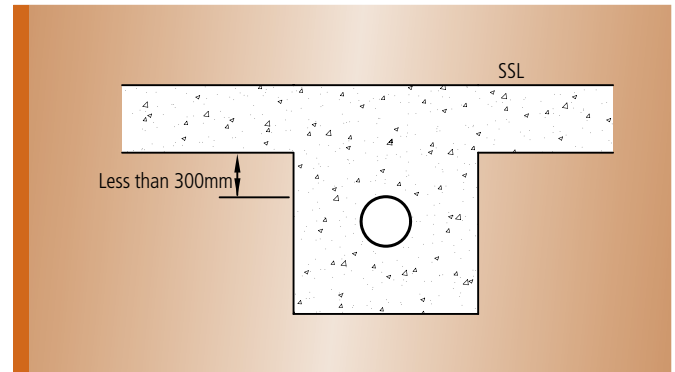

# BELOW GROUND DRAINAGE

## PIPES NEAR BUILDINGS

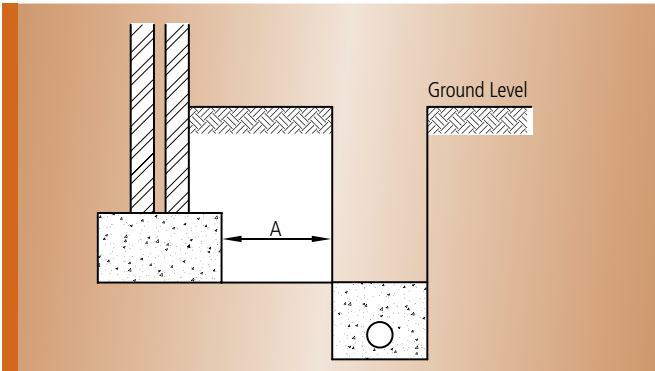

Where dimension A is less than 1.0m, concrete fill trench to level of underside of foundations.

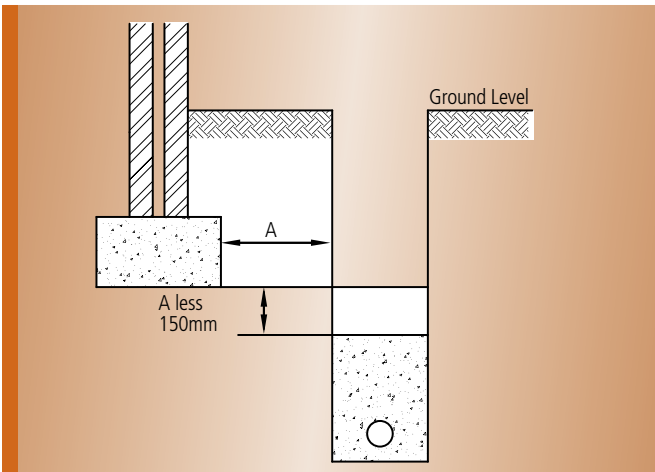

Where dimension A is greater than 1.0m, concrete fill trench to this level.

## JOINT FOR CONCRETE ENCASED PIPE

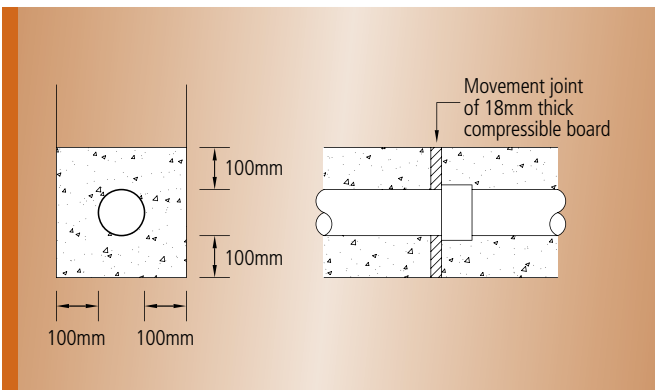

Where pipes are surrounded in concrete to protect nearby foundations, an 18mm compressible board, e.g. fibreboard or polystyrene should be placed around the pipe at each joint.

## PIPES THROUGH WALLS

(a) Short length of pipe bedded in wall with joints formed within 150mm of each wall face.

Adjacent rocker pipes of 600mm max. length with flexible joints.

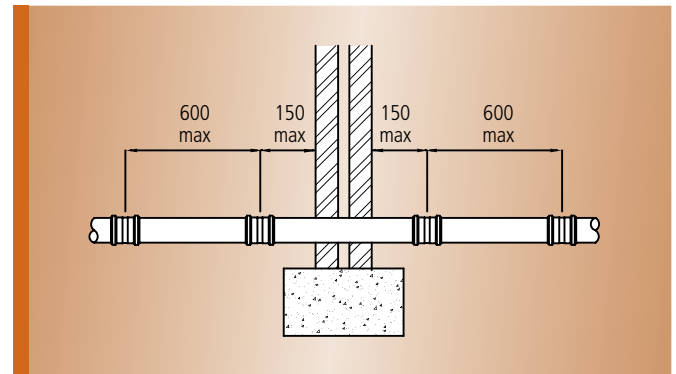

(b) Arch or lintelled opening to give min 50mm space all round the pipe.

Mask opening on both side of the wall with rigid sheet material to prevent entry of fill or vermin.

*Important* Fill void with compressible material to prevent entry of gas.

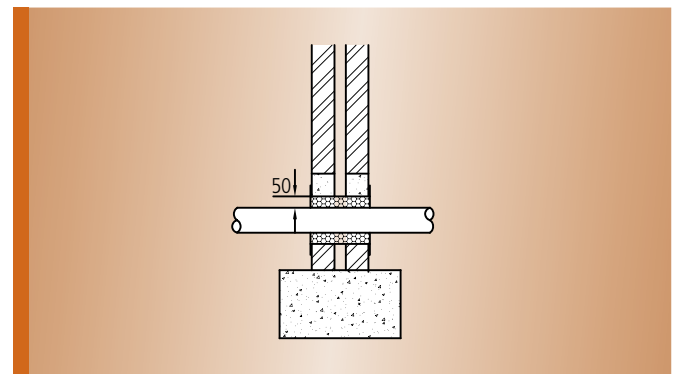

# BELOW GROUND DRAINAGE

## CONNECTION DETAILS

### Waste pipe connection

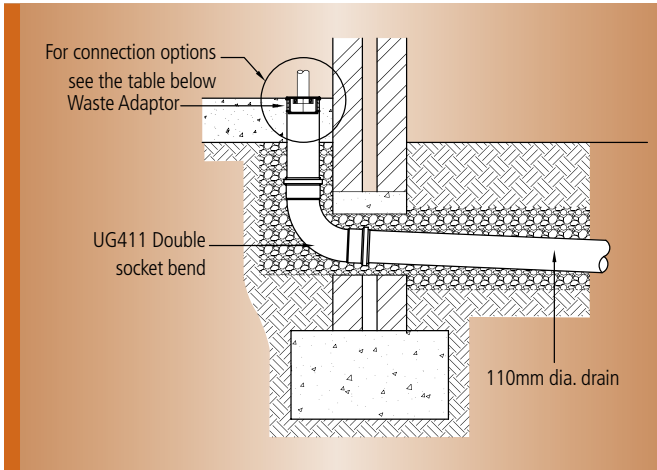

### Rainwater pipe connection

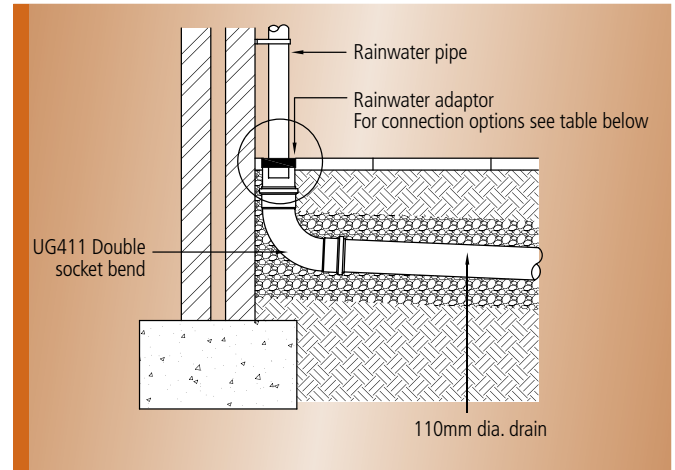

Where a combined drainage system is being used, a trapped gully should be used at the base of the rainwater pipe.

TABLE 19: WASTE PIPE CONNECTION OPTIONS

UG435	UG456 UG457	UG461 UG492
Designed for insertion into 110mm plain pipe.	Designed for insertion into 110mm ring seal socket	
Requires boss adapter	For 32mm waste pipe use UG455	
For 32mm waste pipe use SN32 or SN63	For 40mm waste pipe use UG456	
For 40mm waste pipe use SN40 or SN64	For 50mm waste pipe use UG457	
For 50mm waste pipe use SN50 or SN65	For 32mm and 40mm waste pipes use UG461	
	For 2 no. 40mm waste pipe use UG492	

TABLE 20: RAINWATER CONNECTION OPTIONS

Universal Adaptor - EDPM	Rainwater Adaptor - Polypropylene
UG485 - Locates on 110mm socket	UG253 - Locates on 82mm socket or spigot
UG493 - Locates on 110mm spigot/plain end pipe	UG254 - Locates on 110mm socket or spigot
Will accept all rainwater and waste pipes. For square section rainwater pipe, cut to template indicated on underside.	Will accept 68mm circular rainwater pipe. For square section rainwater pipe, insert RS231 adaptor





# BELOW GROUND DRAINAGE

## Soil pipe/WC connection

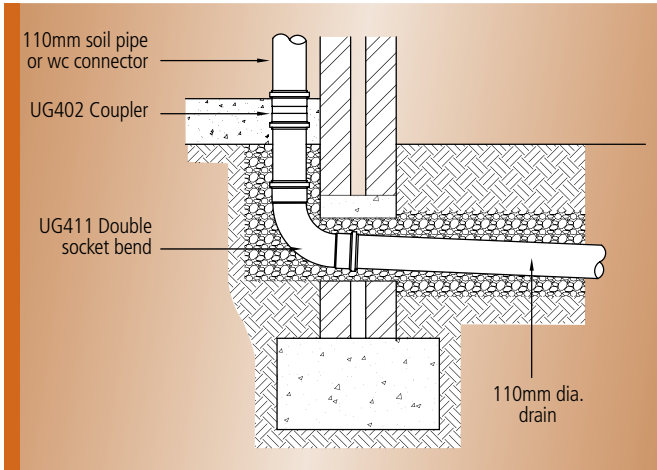

## Bottle gully detail

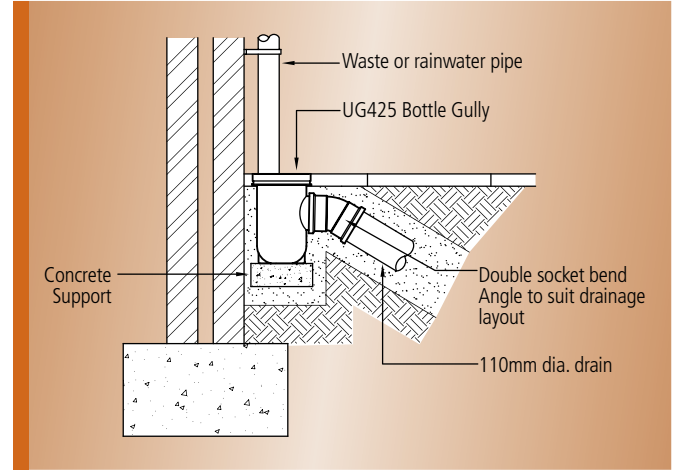

## Back inlet bottle gully detail

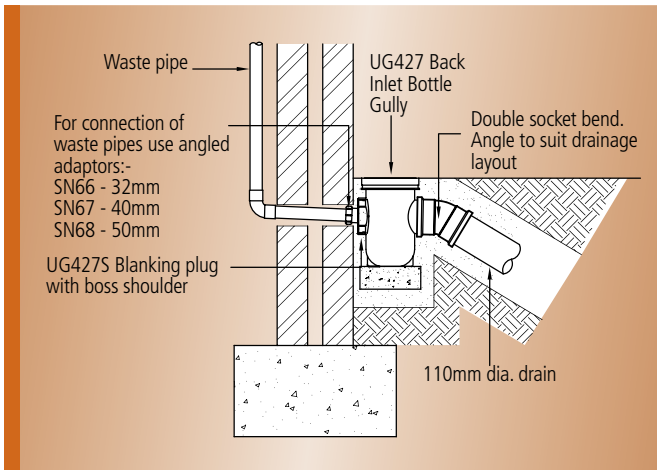

## Rectangular hopper / universal gully trap detail

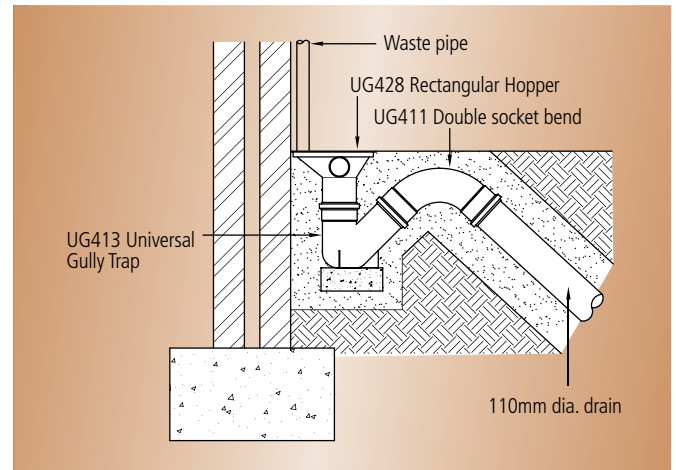

## Rodding eye detail

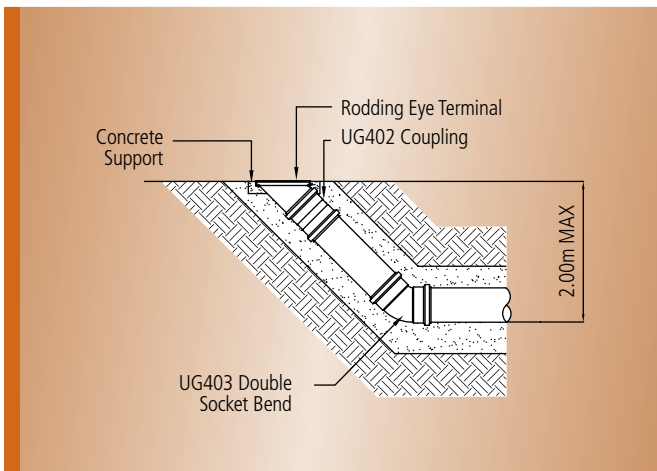



# BELOW GROUND DRAINAGE

## YARD GULLY DETAIL

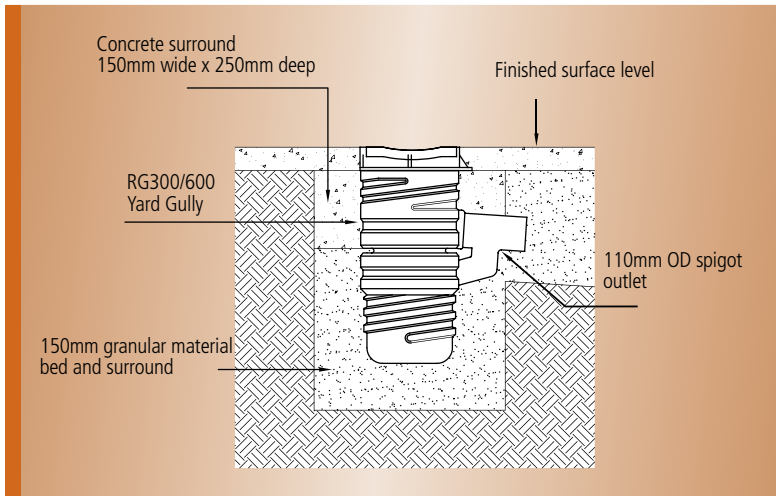

## ROAD GULLY DETAIL

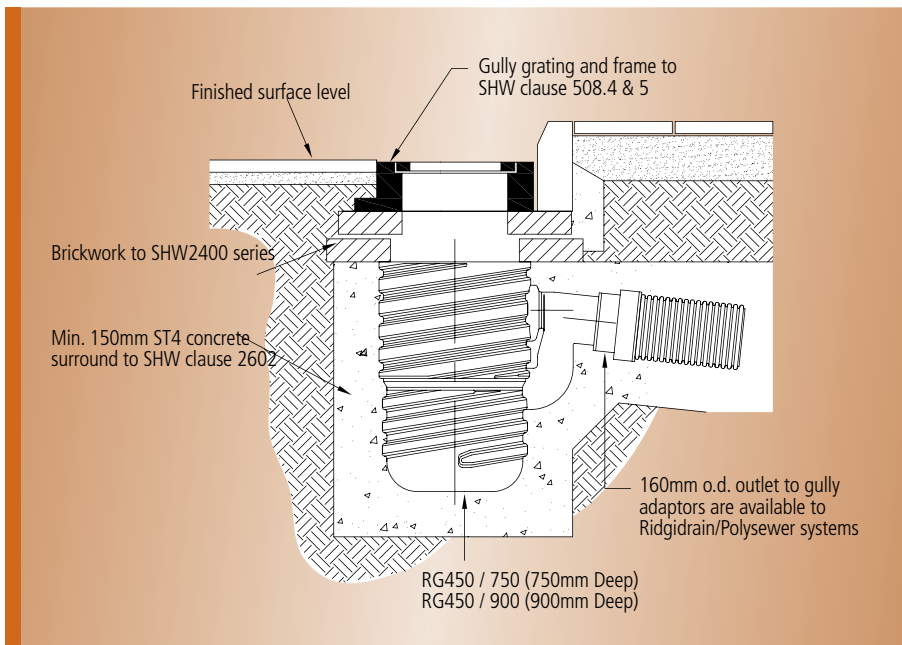

# BELOW GROUND DRAINAGE

## INSPECTION CHAMBERS

### Design Requirements

The layout of the underground drainage system should be kept as simple as possible with the minimum number of changes in direction and gradient. Access points should be provided only if blockages could not be cleared without them.

Connections of drains to other drains should be made obliquely in the direction of flow.

Sewers, i.e. drain serving more than one property, should be kept as far as is practicable away from the point on a building where future extension is likely, e.g. the rear side of a dwelling where there is room for an extension.

The system should be ventilated by a flow of air, normally provided by a ventilating pipe situated at or near the head of each main drain.

Drains should be laid to even gradients and any change of gradient should be combined with an access point.

Recommended minimum gradients for foul and surface water drains are shown in the tables below:

TABLE 21: FOUL DRAINS

Peak Flow (lites/sec)	Pipe Size	Minimum Gradient	Max. Capacity (lites/sec)
< 1	82mm	1:40	4.10
< 1	110mm	1:40	9.20
> 1	82mm	1:80	2.80
> 1	110mm	1:80	6.30
> 1	160mm	1:150*	15.00

\* min 5 WC's

TABLE 22: SURFACE WATER DRAINS

Pipe Size	Minimum Gradient	Max. Capacity (lites/sec)
82mm	1:100	3.50
110mm	1:100	6.90
160mm	1:150	18.20

Note: Building Regulations and Codes of Practice do not recommend maximum gradients for drainage systems.

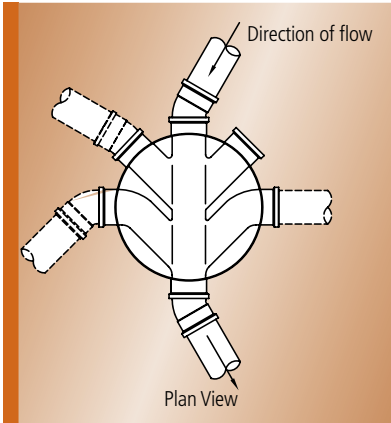

### Chamber Depths

Where the required chamber depth falls between that available with standard risers, the top riser can be cut back using a fine tooth saw to the finished level and slope of surrounding ground.

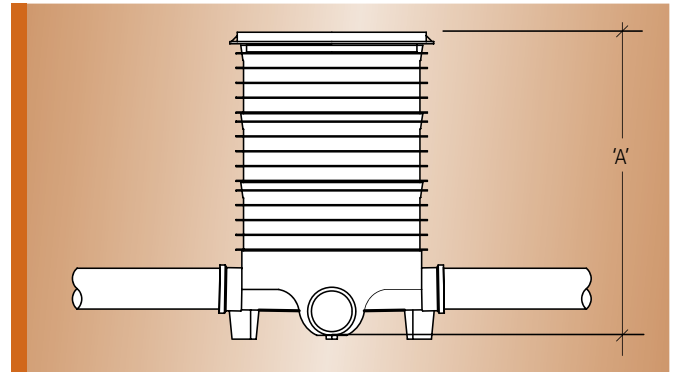

TABLE 23: 320mm SHALLOW INSPECTION CHAMBER BASE DEPTH

	Dim 'A'
+ 1 Riser	314mm
+ 2 Risers	457mm
+ 3 Risers	600mm

TABLE 24: 460mm INSPECTION CHAMBER BASE DEPTH

	Dim 'A'
+ 2 Risers	605mm
+ 3 Risers	803mm
+ 4 Risers	1000mm

Where the depth of the inspection chamber exceeds 1.00m, a 460mm diameter Non-man Entry chamber is available, which can be used up to depths of 4.00m.



# BELOW GROUND DRAINAGE

## Joint Risers

### Section through base of 320mm diameter riser

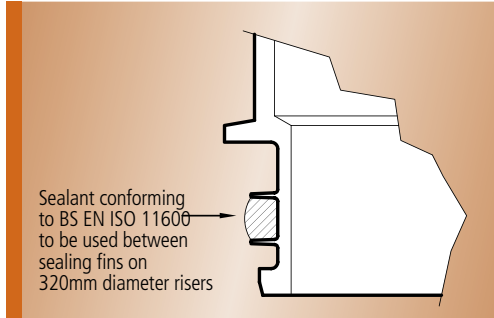

### Section through base of 460mm diameter riser

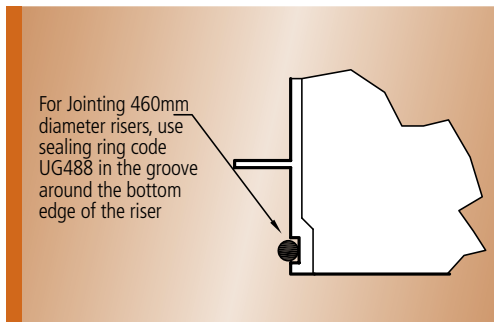

## Cover and Frames

It is important to select a cover and frame with a suitable load classification for the location of the chamber. Load classifications are as follows:

- (A) *Equivalent to Class A15 load category of BS EN 124:1994 (Pedestrians and Pedal Cyclists only)*
- (A+) *Tested to withstand 35kN test load (Light vehicular traffic on domestic drives)*
- (C) *Tested to withstand 10kN test load (Non-vehicular traffic only)*

## Cover and Frames continued

TABLE 25: 320mm DIAMETER COVERS & FRAMES

Product	Classification
UG439 Circular Concrete Cover & PP Frame	A
UG499 Square Concrete Cover & PP Frame	A
UG436 Aluminium Sealed Cover & Frame	C
UG501 Circular PVC Sealed Cover & Frame	C
UG502 Square PVC Sealed Cover & Frame	C

TABLE 26: 460mm DIAMETER COVERS & FRAMES

Product	Classification
UG497 Circular Concrete Cover & PP Frame	A
UG419 Cast Iron Cover & Cast Iron Frame	A
UG444 Cast Iron Cover & PP Frame	A
UG511 Circular PVC Cover & Frame	A+
UG512 Square PP Sealed Cover & Frame	A+
UG513 Square Cast Iron Cover & Cast Iron Frame	B125

Where a heavier duty cover is required, UDC700 (320mm) and UDC750 (460mm) circular ductile iron cover and frames are available to BS EN 124/B125 tested to withstand 125kN test loads. The UG513 square cast iron cover and frame for the 460mm diameter chamber also meets this requirement.

URP720 (320mm) and URP760 (460mm) recessed pavior covers are available which will withstand a 100kN test load.

*NOTE: Where specified, plastic frame to riser fixing kits should be used, see the current Trade Price List for details.*





# BELOW GROUND DRAINAGE

## Cover for Internal Use

The current Building Regulations do not require that internal inspection chambers have a double seal cover. Contact Polypipe technical service for further details on 01709 770 000 - option 2.

## Inspection Chamber Details

### 320mm Shallow Inspection Chamber Detail

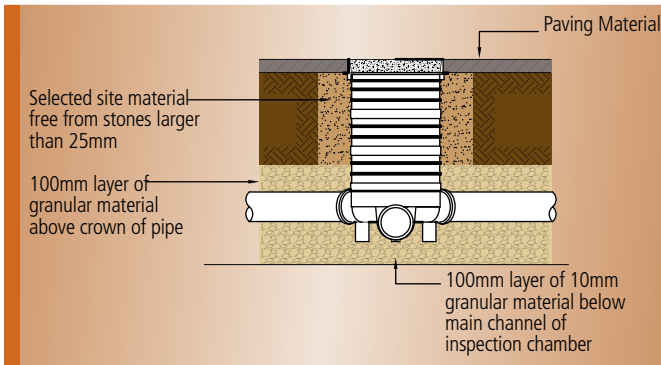

### 460mm Diameter Inspection Chamber Detail

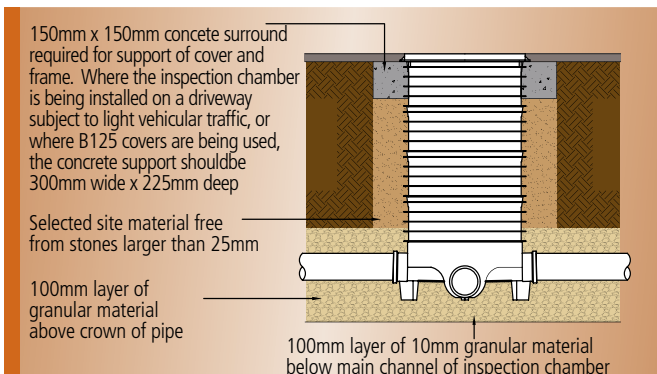

1. In all installations, the main channel of the inspection chamber should always be used. Where the chamber is being used as a change or direction for the drainage system, short radius bends of 11 1/4°, 15°, 30° and 45° can be used in the inlet and outlet to achieve the required angle.
2. Side inlet branch connections enter the inspection chamber approx. 55mm above the invert of the main channel.
3. 320mm diameter chambers are supplied with 2 no. blanking plugs for the side inlets and 460mm diameter chambers are supplied with 3 no. blanking plugs.

## TESTING OF BELOW GROUND DRAINAGE SYSTEMS

Following installation, all sections of the underground drainage system should be inspected for obstructions, straightness and water infiltration.

The current Building Regulations require that drains should be tested for water tightness by means of an air test or water test as detailed below:-

### Air Test

For pipes up to 300mm diameter, the pipe should be pressurised to a pressure of 110mm water gauge and held for approx. 5 minutes prior to testing.

Following this, the pipe should be able to hold an initial 100mm pressure with a maximum loss of head on a manometer of 25mm in a period of 7 minutes.

### Water Test

For pipes up to 300mm diameter, the system should be filled with water up to a depth of 500mm above the lowest invert in the test section and a minimum depth of 100mm measured at the highest invert in the test section.

This may then be left for a period (one hour is generally sufficient) to condition the pipe. The test pressure should then be maintained for a period of 30 minutes, by topping up the water level as necessary so that it is within 10mm of the required level throughout the test.

The losses per square metre of surface area should not exceed 0.15 litres for test lengths with only pipelines or 0.20 litres for test lengths including pipelines and manholes, or 0.4 litres for tests with only manholes and inspection chambers alone (i.e. no pipelines).





# BELOW GROUND DRAINAGE

## POLYSEWER

### Specification

150mm to 300mm bore PVC structured wall pipes for use in gravity sewers to the WIS 4-35-01 specification.

Polysewer is in accordance with BSI Kitemark Licence Number KM55698 to WIS 4-35-01 Specification for Thermoplastic Structured Wall Pipes, Joint and Couplers with a Smooth Bore for Gravity Sewers for the Size Range 150-300 inclusive.

WIS 4-35-01 gives the material and testing requirements for structured wall pipes, which are to be used in gravity sewer systems.

Tests included within the specification cover long term structural performance, joint integrity under extreme loads and for the first time in the UK specification, resistance to potential damage for cleaning and maintenance procedures.

### Installer and Specifier Benefits

- Durable but lightweight pipes and fittings manufactured for ease of handling on and off site, also reduces health and safety risks.
- Up to 6m pipe lengths requiring fewer joints than traditional materials.
- Proven long term stiffness to resist deformation when buried.
- Pipes retain flexibility to accommodate ground settlement.
- Resistant to biological and chemical attack.
- Manufactured from recyclable materials.

### System Maintenance

Where the material of an existing sewer is unknown the WRC Code of Practice recommends a maximum jetting pressure of 130 bar due to the high risk of damage to ageing sewers.

Although Polysewer pipes are manufactured to withstand jetting pressures up to 180 bar for 2 minutes in the Jetting Type test, research has proven plastic pipes can be cleared at much lower pressures.

As conventional drain rods are still widely used to clean sewers Polysewer pipes are resistant to damage from internal impact as laid out in WIS 4-35-01.

To ensure long term performance, pipes have been manufactured to remain flexible in situations where ground movement may occur whilst maintaining a resistance to deformation when buried. Polysewer PVC pipes are manufactured to comply with stiffness Class 8 as detailed in WIS 4-35-01.



# FURTHER ADVICE

Polypipe building Products also offer product and technical advice on the following ranges:

- Cold Water Supply Systems
- Polyguard Barrier Pipe System, including the plastic fittings range
- Polyfast Compression Fittings
- Rainstream Rainwater Harvesting System and Re-cycled Rainwater Pipes
- Polystorm Modular Water Storage units
- TDI Cavity Closers and DPC
- Loft Hatches



All above product ranges and systems are itemised in the current Polypipe Trade Price List



AVAILABLE AS DOWNLOAD ONLY

## Further Assistance

If you need any further help or advice, please contact:

Technical Advice: **01709 770 000 - option 2**

Sales/Delivery: **01709 770 000 - option 1**

Contact your local Polypipe Area Manager

Alternatively please visit our website at **[www.polypipe.com/bp](http://www.polypipe.com/bp)** and follow the Literature Downloads link.



# Technical Installation Guide Above & Below Ground Drainage



## Polypipe Building Products

Broomhouse Lane  
Edlington  
Doncaster DN12 1ES  
Tel: 01709 770 000  
Fax: 01709 770 001

2410 London Road  
Mount Vernon  
Glasgow G32 8XZ  
Tel: 0141 778 8822  
Fax: 0141 778 2703

Dromore Road  
Lurgan, Craigavon  
Co. Armagh BT66 7HL  
Tel: 028 38 881270  
Fax: 028 38 882344